

**TM 55-1730-224-13&P**

---

**TECHNICAL MANUAL  
OPERATOR'S, AVIATION UNIT,  
AND INTERMEDIATE MAINTENANCE MANUAL  
INCLUDING  
REPAIR PARTS AND SPECIAL TOOLS LIST**

for

**TRAILER,  
AIRCRAFT MAINTENANCE,  
AIRMObILE  
PART NUMBER  
22142**

**NSN 1730-00-435-7818**

This copy is a reprint which includes current  
pages from Changes 1 through 3.

---

**HEADQUARTERS, DEPARTMENT OF THE ARMY  
15 SEPTEMBER 1982**

HEADQUARTERS  
DEPARTMENT OF THE ARMY  
WASHINGTON, D.C., 1 FEBRUARY 1994

Operator's, Aviation Unit,  
and Intermediate Maintenance Manual

Including

Repair Parts and Special Tools List

for

TRAILER,  
AIRCRAFT MAINTENANCE,  
AIRMOBILE  
PART NUMBER 22142  
NSN 1730-00-435-7818

DISTRIBUTION STATEMENT A: Approved for public release; distribution is unlimited.

TM 55-1730-224-13&P, 15 September 1982, is changed as follows:

1. Remove and insert pages as indicated below. New or changed text material is indicated by a vertical bar in the margin. An illustration change is indicated by a miniature pointing hand.

Remove pages

i and ii  
1-1 and 1-2  
A-1/(A-2 blank)  
C-7 through C-10  
C-13 and C-14  
----  
C-15 and C-16  
----

Insert pages

i and ii  
1-1 and 1-2  
A-1/(A-2 blank)  
C-7 through C-10  
C-13 and C-14  
C-14.1/(C-14.2 blank)  
C-15 and C-16  
C-16.1/(C-16.2 blank)

Retain this sheet in front of manual for reference purposes.

TM 55-1730-224-13&P  
C 3

By order of the Secretary of the Army:

GORDON R. SULLIVAN  
*General, United States Army*  
*Chief of Staff*

Official:

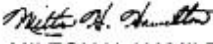
  
MILTON H. HAMILTON  
*Administrative Assistant to the*  
*Secretary of the Army*  
06303

DISTRIBUTION:

To be distributed in accordance with DA Form 12-31-E, block no. 0846, requirements for TM 55-1730-224-13&P.

CHANGE

No. 2

HEADQUARTERS  
DEPARTMENT OF THE ARMY  
WASHINGTON, D.C., 6 September 1991

Operator's, Aviation Unit,  
and Intermediate Maintenance Manual

Including

Repair Parts and Special Tools List

for

TRAILER,  
AIRCRAFT MAINTENANCE,  
AIRMOBILE  
PART NUMBER  
22142  
NSN 1730-00-435-7818

TM 55-1730-224-13 & P, 15 September 1982, is changed as follows:

1. Remove and insert pages as indicated below. New or changed text material is indicated by a vertical bar in the margin. An illustration change is indicated by a miniature pointing hand.

Remove pages

i and ii  
1-1 and 1-2  
A-1/A-2  
C-9 and C-10  
C-13 and C-14  
C-15 and C-16

Insert pages

i and ii  
1-1 and 1-2  
A-1/A-2  
C-9 and C-10  
C-13 and C-14  
C-15 and C-16

2. Retain this sheet in front of manual for reference purposes.

**By Order of the Secretary of the Army:**

Official:

**PATRICIA P. HICKERSON**  
*Colonel, United States Army*  
*The Adjutant General*

**GORDON R. SULLIVAN**  
*General, United States Army*  
*Chief of Staff*

DISTRIBUTION:

To be distributed in accordance with DA Form 12-39-E, block no 0846, -10 & CL, AVUM and AVIM maintenance requirements for TM 55-1730-224-13 & P.

CHANGE }  
NO. 1 }

HEADQUARTERS  
DEPARTMENT OF THE ARMY  
WASHINGTON, D.C., 1 April 1988

Operator's, Aviation Unit,  
and Intermediate Maintenance Manual

Including

Repair Parts and Special Tools List

for

TRAILER,  
AIRCRAFT MAINTENANCE,  
AIRMOBILE  
PART NUMBER  
22142  
NSN 1730-00-435-7818

TM 55-1730-224-13 & P, 15 September 1982, is changed as follows:

1. Remove and insert pages as indicated below. New or changed text material is indicated by a vertical bar in the margin. An illustration change is indicated by a miniature pointing hand.

Remove pages

i and ii  
1-1 and 1-2  
2-3 and 2-4  
3-1 and 3-2  
A-1/A-2  
B-3 through B-6  
C-1 through C-11

Insert pages

i and ii  
1-1 and 1-2  
2-3 and 2-4  
3-1 and 3-2  
A-1/A-2  
B-3 through B-6  
C-1 through C-16

2. Retain this sheet in front of manual for reference purposes.

By Order of the Secretary of the Army:

CARL E. VUONO  
*General, United States Army*  
*Chief of Staff*

Official:

R. L. DILWORTH  
*Brigadier General, United States Army*  
*The Adjutant General*

DISTRIBUTION:

To be distributed in accordance with DA Form 12-31, AVUM & AVIM Maintenance requirements for All Fixed and Rotary Wing Aircraft.

WARNING

LOAD CAPACITY

Do not load trailer to more than 4000 lbs.

TOWING

Do not tow faster than 20 m.p.h. Release brake before towing.

PARKING

Set parking brake on trailer and towing vehicle when parked.

COUPLING RAILS

Do not get between trailers. Keep fingers clear. Set brakes.

LIFTING PALLETS

Set brakes before lifting. Place fork thru both sides of pallet. Remove bolster pins before lifting. Do not get under load until it rests firmly on trailer.

JACKING

Do not get under trailer when it is supported only by jack.

TECHNICAL MANUAL

No. 55-1730-224-13&P

Headquarters  
Department of the Army  
Washington, D.C., 15 September 1982

OPERATOR'S, AVIATION UNIT,  
AND INTERMEDIATE MAINTENANCE MANUAL

INCLUDING

REPAIR PARTS AND SPECIAL TOOLS LIST

for

TRAILER, AIRCRAFT MAINTENANCE, AIRMOBILE  
PART NUMBER 22142  
NSN 1730-00-435-7818

REPORTING ERRORS AND RECOMMENDING IMPROVEMENTS

You can help improve this manual. If you find any mistakes or if you know of a way to improve the procedures, please let us know. Mail your letter, DA Form 2028 (Recommended Changes to Publications and Blank Forms), or DA Form 2028-2 located in the back of this manual direct to Commander, US Army Aviation and Troop Command, ATTN: AMSAT-I-MP, 4300 Goodfellow Blvd., St. Louis, MO 63120-1798. A reply will be furnished directly to you.

**DISTRIBUTION STATEMENT A: Approved for public release; distribution is unlimited.**

TABLE OF CONTENTS

	Page
CHAPTER 1. INTRODUCTION	
Section I. General Information . . . . .	1-1
Section II. Equipment Description and Data . . . . .	1-2
Section III. Principle of Operation . . . . .	1-4
CHAPTER 2. OPERATION INSTRUCTIONS	
Section I. Description and Use of Operator's Controls . . . . .	2-1
Section II. Preventive Maintenance checks and Services . . . . .	2-3
Section III. Operation Under Usual Conditions . . . . .	2-3
CHAPTER 3. MAINTENANCE INSTRUCTIONS (AVUM AND AVIM)	
Section I. Repair Parts, Special Tools, TMDE and Support Equipment . . . . .	3-1
Section II. Service Upon Receipt . . . . .	3-1
Section III. Preventive Maintenance Checks and Services . . . . .	3-13
Section IV. Troubleshooting . . . . .	3-15
Section V. Maintenance Procedures . . . . .	3-16

TABLE OF CONTENTS (cont)

APPENDIX		Page
APPENDIX A	REFERENCES	A-1
APPENDIX B	MAINTENANCE ALLOCATION CHART	B-1
APPENDIX C	REPAIR PARTS AND SPECIAL TOOLS LIST	C-1
ALPHABETICAL	INDEX	Index 1

LIST OF TABLES

Number	Title	Page
1-1	Leading Particulars	1-2
2-1	Operator's Controls	2-1
2-2	Operator/Crew Preventive Maintenance Checks and Services	2-3
3-1	Service Upon Receipt	3-1
3-2	Preliminary Servicing of Equipment	3-10
3-3	AVUM PMCS	3-13
3-4	Troubleshooting Procedures	3-15
3-5	Trailer Assemblies	3-16
3-6	Towbar Maintenance Checklist	3-17
3-7	Front Axle and Steering Assembly Maintenance	3-21
3-8	Brake Maintenance Checklist	3-24
3-9	Rear Axle Maintenance Checklist	3-25
3-10	Wheel Assembly Maintenance Checklist	3-27
3-11	Rail Assembly Maintenance Checklist	3-28
3-12	Pallet and Bolster Maintenance Checklist	3-30

LIST OF ILLUSTRATIONS

Number	Title	Page
1-1	Trailer, Aircraft Maintenance, Airmobile	1-1
1-2	Major Components	1-3
2-1	Operator's Controls	2-2
3-1	Assemblies for Maintenance	3-16
3-2	Wiring Diagram	3-31



## CHAPTER 1

## INTRODUCTION

## Section I - General Information

## 1-1. SCOPE.

a. Type of Manual: Operator's, Aviation Unit and Intermediate Maintenance.

b. Model Number and Equipment Name: Part Number 22142 Trailer, Aircraft Maintenance Airmobile. Refer to figure 1-1.

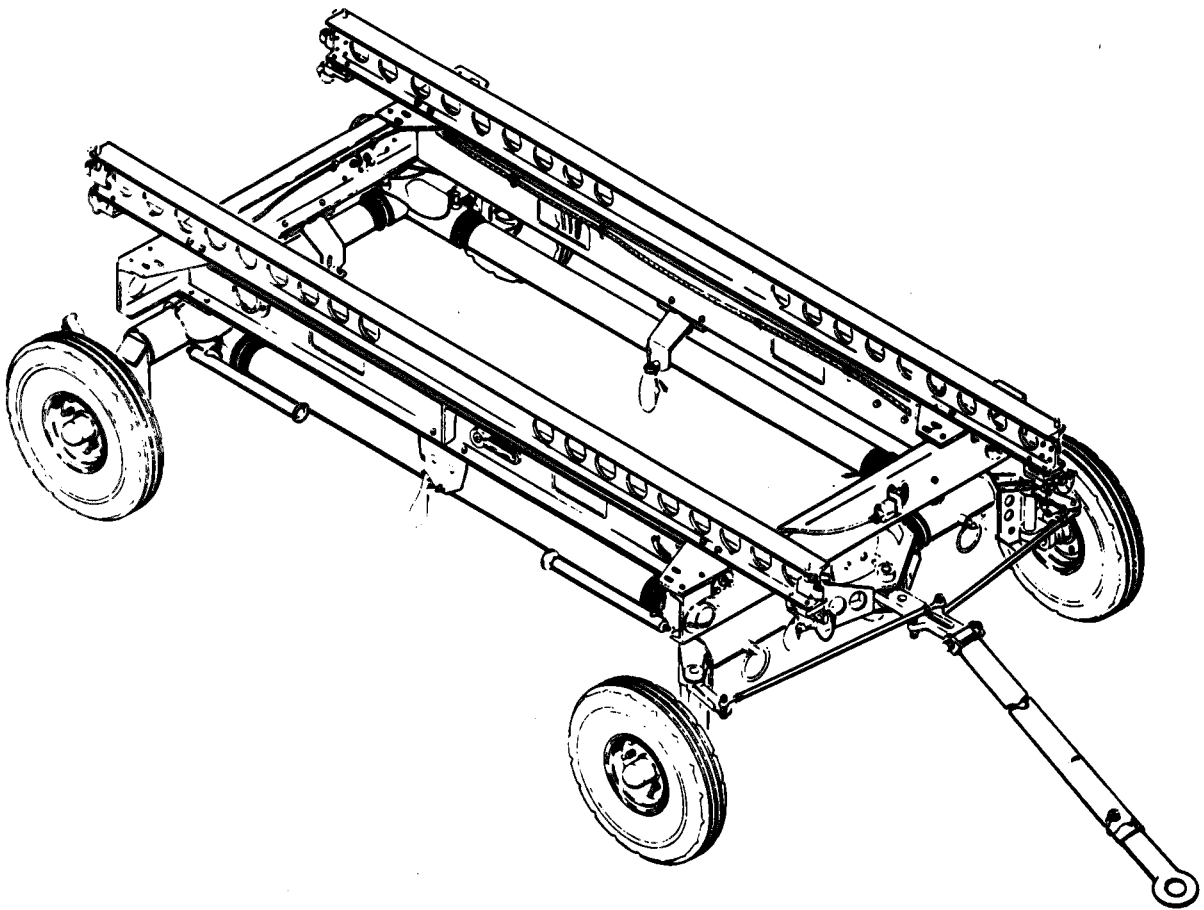

Figure 1-1. Trailer, Aircraft Maintenance, Airmobile

c. Purpose of Equipment: Transports materiel during aircraft maintenance.

**1-2. MAINTENANCE FORMS, RECORDS, AND REPORTS.** Department of the Army forms and procedures used for equipment maintenance will be those prescribed by DA PAM 738-751, The Functional Users Manual for Army Maintenance Management System Aviation (TAMMS-A).

1-3. DESTRUCTION OF ARMY MATERIEL TO PREVENT ENEMY USE. Refer to TM 750-244-1-3, Procedure for Destruction of Aviation Support Equipment (FSC 1700), for instructions on destroying this equipment.

1-4. REPORTING EQUIPMENT IMPROVEMENT RECOMMENDATIONS (EIR). EIR can and must be submitted by anyone who is aware of an unsatisfactory condition with the equipment design or use. It is not necessary to show anew design or list a better way to perform a procedure, just simply tell why the design is unfavorable or why a procedure is difficult. EIR will be submitted on SF 368 (Quality Deficiency Report) in accordance with DA PAM 738-751. DA Form 2407 will no longer be used to submit EIRs as stated in DA PAM 738-751. Mail directly to: Commander, Headquarters, U.S. Army Aviation and Troop Command, ATTN: AMSAT-I-MDO, 4300 Goodfellow Blvd., St. Louis, MO. 63120-1798. A reply will be furnished to you.

Section II. Equipment Description and Data

1-5. CHARACTERISTICS, CAPABILITIES AND FEATURES

Characteristics

- **Transports**

Capabilities and Features

- Can travel over rough terrain,
- Can be loaded or unloaded by sliding load to or from another trailer,
- Can be loaded and unloaded by lifting with a fork lift,
- Can be towed together with other trailers.

1-6. LOCATION AND DESCRIPTION OF MAJOR COMPONENTS (Refer to figure 1-2 and table 1-1).

Table 1-1. Leading Particulars

Length . . . . .	136-3/8 inches (max) Towbar fully extended
Width . . . . .	68-3/4 - 1/2 inches
Height . . . . .	38-1/8 inches (max)
Operating Temperature . . . . .	-65°F to 125°F
Load Capacity . . . . .	4000 pounds (max)
Corner Articulation . . . . .	10-5/8 inch (rein)
Pallet Width . . . . .	10-5/8 inch (rein)
Rail Length . . . . .	110±1/4 inch
Towing Speed . . . . .	20 mph (max)
Tire Pressure . . . . .	65 psig
Wheel Base . . . . .	84±1/2 inch
Cramp Angle . . . . .	40 degrees (rein)
Lighting Assembly Operating Voltage . . . . .	24 to 28 Volts dc
Unloaded Trailer Weight . . . . .	644 pounds (approx)

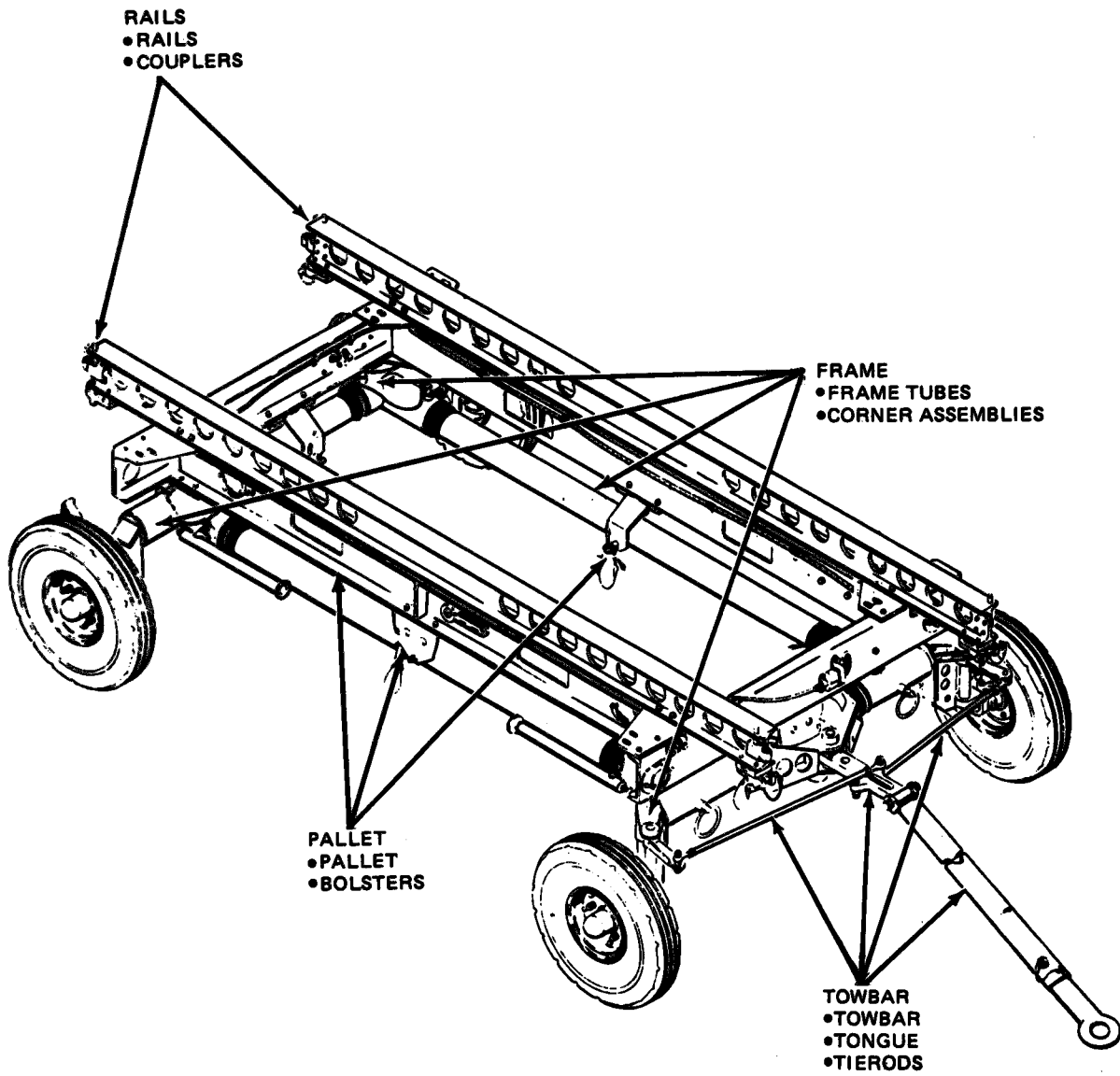

Figure 1-2. Major Components

Section III. Principles of Operation

1-7. FRAME. The frame pivots and allows the wheels to follow the ground. If one wheel of the trailer is low, the rails will stay parallel. This keeps the trailer and the load from being twisted.

1-8. PALLET. The pallet can be disconnected from the frame. This lets the operator unload the trailer with a fork lift.

1-9. RAILS. The rails of two trailers can be connected. This lets the operator load or unload the trailer by sliding or rolling the load onto another trailer.

## CHAPTER 2

## OPERATING INSTRUCTIONS

## Section I. Description and Use of Operators Controls

2-1. OPERATOR'S CONTROLS. Use Table 2-1 and Figure 2-1 to find location and purpose of operator's controls.

Table 2-1. Operator's Controls

ILLUSTRATION ITEM NUMBER	NAME	PURPOSE
13, 16 (16 hidden)	Brake handle	Holds trailer for parking.
8	Tow bar	Pulls and steers trailer.
1, 5, 10, 12 (1 and 5 hidden)	Jacks	Makes trailer level; lifts trailer for changing wheels
6, 9, 14, 17	Rail couplers w/locking pins	Connect rails together.
3, 4, 11, 15 (4 hidden)	Bolsters w/locking pins	Connects pallet to frame.
7	Plug connector	Connects wiring harness of trailer to tow vehicle.
2	Tie down ring	Secures load

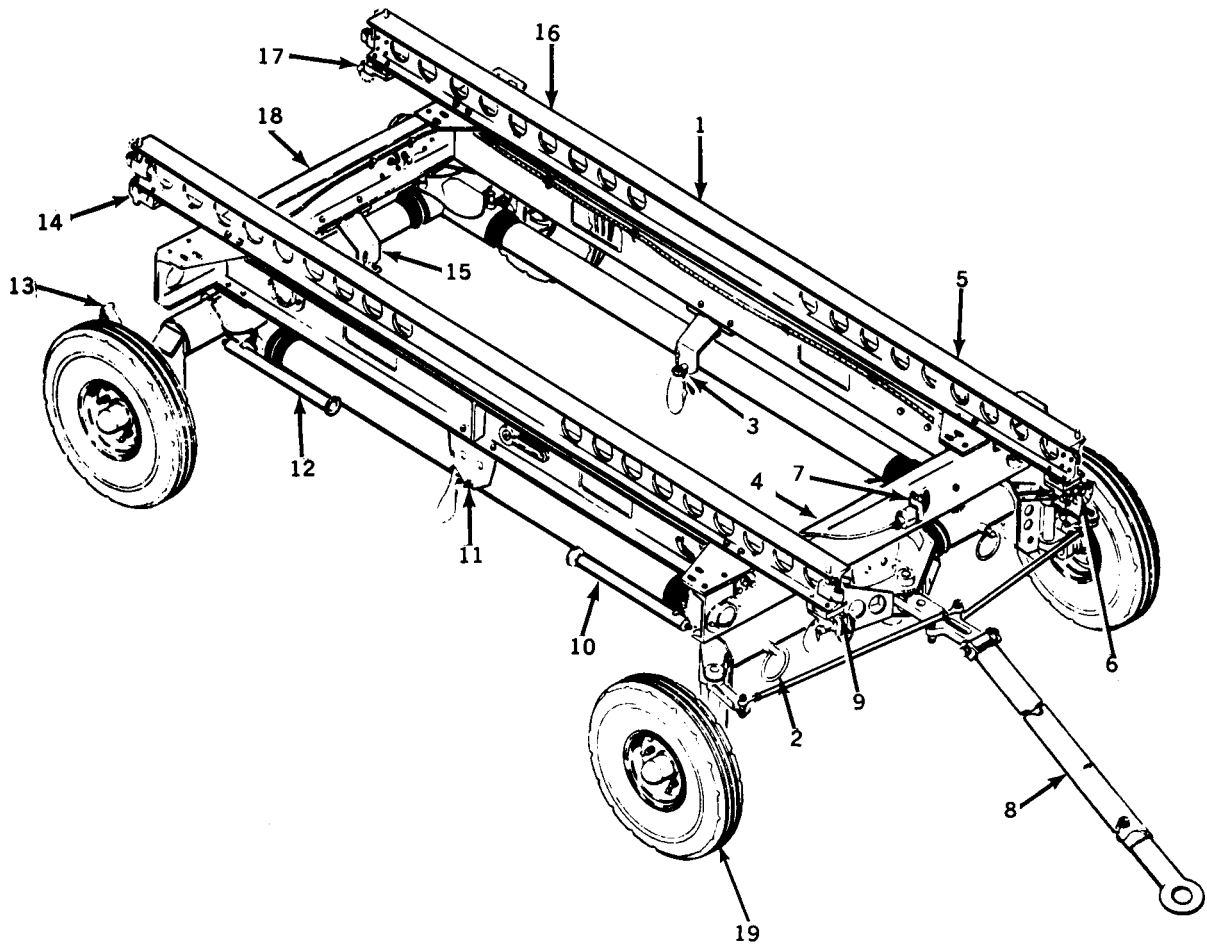

- |              |            |
|--------------|------------|
| 1. Jack      | 11. Pin    |
| 2. Ring      | 12. Jack   |
| 3. Pin       | 13. Handle |
| 4. Pin.      | 14. Pin    |
| 5. Jack      | 15. Pin    |
| 6. Pin       | 16. Handle |
| 7. Connector | 17. Pin    |
| 8. Tow bar   | 18. Pallet |
| 9. Pin       | 19. Tire   |
| 10. Jack     |            |

Figure 2-1. Operator's Controls

Section II. Preventive Maintenance Checks and Services

2-2. BEFORE YOU OPERATE. Always keep in mind the CAUTIONS and WARNINGS. Check tire pressure daily. See Table 2-2 for complete instructions.

Table 2-2. Operator/Crew Preventive Maintenance Checks and Services

NOTE

Within designated intervals, these checks are to be performed in the order listed.

Item No.	Interval					Item to be Inspected	Procedures Check for and have repaired or adjusted as necessary	Equipment is Not Ready/ Available If:
	B	D	A	W	M			
1				•		<b>Jack</b>	Check jack for looseness or binding	Jack is not secured properly.
2	•	•	•			<b>Nuts, Bolts</b>	Check all mounting hardware for damage or looseness.	If mounting hardware is not tight or is damaged.
3	•	•				<b>Lube Fittings</b>	Check, and report to AVUM.	If not properly lubricated.

2-3. IF YOUR EQUIPMENT FAILS TO OPERATE. Troubleshoot with proper equipment. Report any deficiencies using proper forms. See DA PAM 738-751.

Section III. Operation Under Usual Conditions

2-4. COUPLING AND TOWING.

Coupling

1. Connect towbar (1) of trailer to pintle hook (2) of tow vehicle.

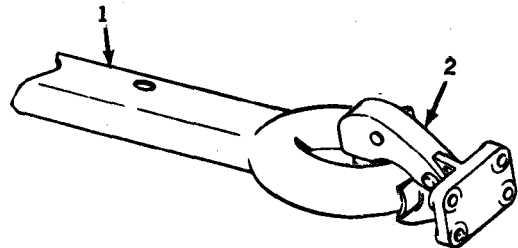

2. Connect plug connector on trailer to plug connector on tow vehicle.

WARNING

Do not tow faster than 20 mph. Release brakes before towing.

Towing

1. Release brakes.
2. Tow at speed less than 20 mph.

WARNING

Do not get between trailers. Keep fingers clear. Set brakes

2-5. Coupling rails

1. Position trailers so that rail couplers (1, 2, 3, 4,) are in line.

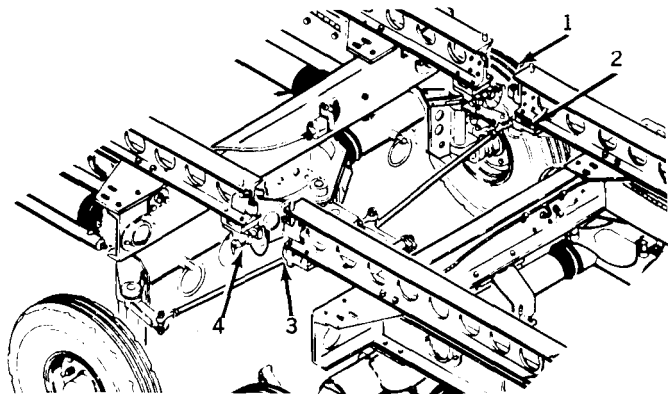

2. Remove pins (3) in rail couplers (1 and 2).

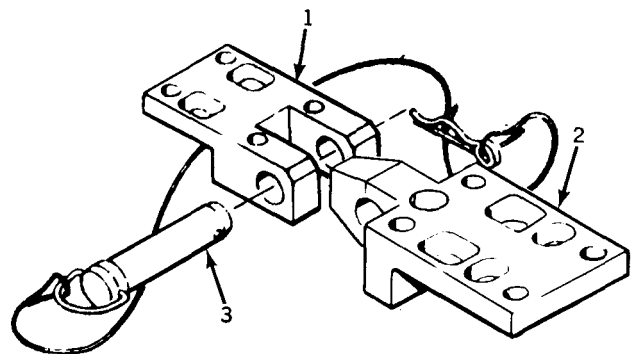

3. Push trailers together.
4. Push pins (1) in place. Secure with tube locking cross pin (2). Set brakes.
5. Slide load.
6. Remove cross pins, locking pins and release brakes.

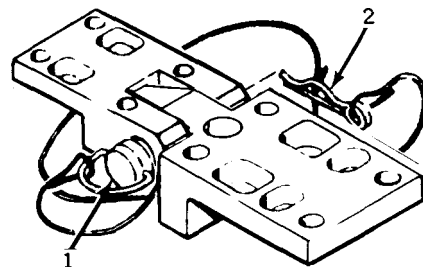



## 2-6. REMOVING AND REINSTALLING PALLETS.

WARNING

Set brakes before lifting. Place fork of fork lift thru both sides of pallet before lifting. Remove locking pins of bolsters before lifting. Do not get under load when supported only by fork lift.

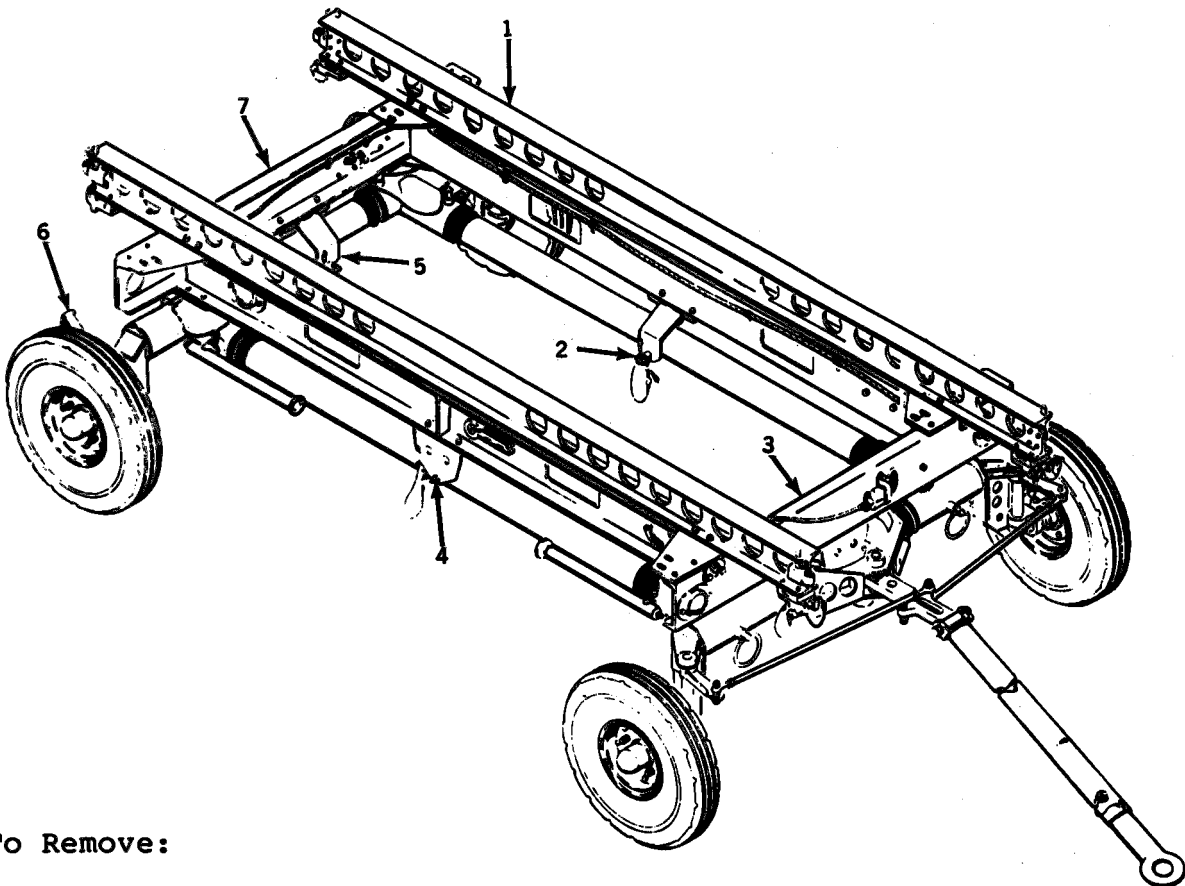
**To Remove:**

1. Set brakes (1) and (6).
2. Position fork of fork lift through slots on both sides of pallet..
3. Remove bolster pins (5), (2), (3), and (4).
4. Lift pallet (7).

**To Reinstall:**

1. Lower pallet (7).
2. Align holes and reinstall lock pins in bolsters.

2-7. OPERATING JACKS

WARNING

Do not get under trailer when it is supported by only the jack. Use safety stands. Block wheels when jacking. Set brakes.

1. Remove ball-lok pin (1) and place jack (3) in vertical position.
2. Reinstall ball-lok pin (1).
3. Operate handle (2) to raise trailer.
4. Operate handle (2) to lower trailer.
5. Pull out ball-lok pin (1) and place jack (3) in horizontal position.
6. Secure jack with ball-lok pin.

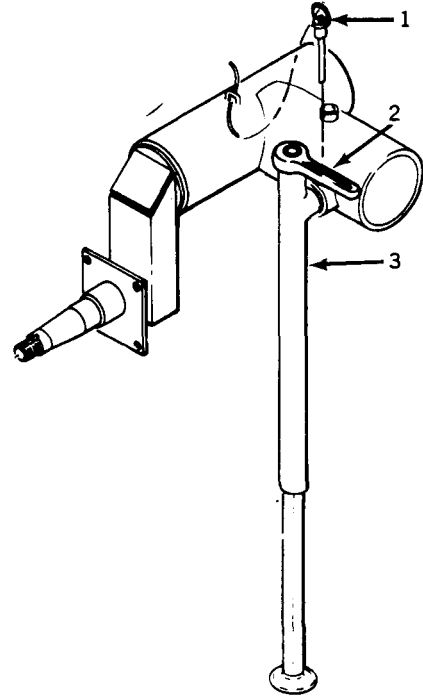

CHAPTER 3

MAINTENANCE INSTRUCTIONS: AVUM AND AVIM

Section I. Repair Parts, Special Tools, TMDE and Support Equipment

3-1. COMMON TOOLS AND EQUIPMENT. For authorized common tools and equipment refer to the Modified Table of Organization and Equipment (MTOE) applicable to your unit.

For AVUM, Tool Set, Aircraft Mechanics, General [NSN 5180-00-323-46921  
 For AVIM, Tool Set, Aircraft Mechanics, General [NSN 5180-00-323-46921  
 and Shop Set, Sheet Metal [NSN 4920-00-166-5505]

3-2. SPECIAL TOOLS, TMDE, and support equipment. No special tools required.

3-3. REPAIR PARTS. Repair parts are listed and illustrated in Appendix C of this manual.

Section II. Service Upon Receipt

Table 3-1. Service Upon Receipt

LOCATION	ITEM	ACTION	REMARKS
Container	Components	Inspect for damage	Para. 3-4
Packing Slip, contents of container	List, parts shipped	Compare list to what was shipped	Para. 3-4
Contents of container	All parts	Check for modified parts	Para. 3-4

3-4. CHECKING UNPACKED EQUIPMENT

1. Inspect the equipment for damage incurred during shipment. If the equipment has been damaged, report the damage on DD Form 6, Packaging Improvement Report.

2. Check the equipment against the packing slip to see if the shipment is complete. Report all discrepancies in accordance with instructions of DA PAM 738-751.

3\* Check to see whether the equipment has been modified.

3-5. ORDER OF ASSEMBLY. Here is the order of assembly to follow:

1. Corner assemblies to frame tubes. See 3-6 below.
2. Bolster assemblies to frame. See 3-7.

3. Pallet assembly to bolsters.  
See 3-8.
4. Tongue to frame. See 3-9.
5. Tie rods to tongue and corner assemblies. See 3-10.
6. Tow bar to tongue. See 3-11.
7. Rails to pallet. See 3-12.
8. Jacks to frame tubes. See 3-13.

CAUTION

Do not force parts together. Align assemblies before pushing in place.

3-6. CORNER ASSEMBLIES TO FRAME TUBES.

1. Place the four corner assemblies where they will be on finished trailer.
2. Place rubber boot (10) over right front corner assembly tube (2) and fold back. Keep rubber boot (7) aside to use later.
3. Place tongue bracket (9) on right front corner assembly.
4. Place bolt (8) through holes and start nuts (4) with washers (3). Do not tighten.
5. Place rubber boot (7) on right front corner assembly. Fold the boot back.
6. Slide front tube (6) into right front corner assembly.
7. Align holes and push lock pin.
8. Tighten nuts on tongue mounting bracket.
9. Slide side tube (11) into right front corner assembly (2).
10. Align holes and push lock pin (1) and (5) in place.

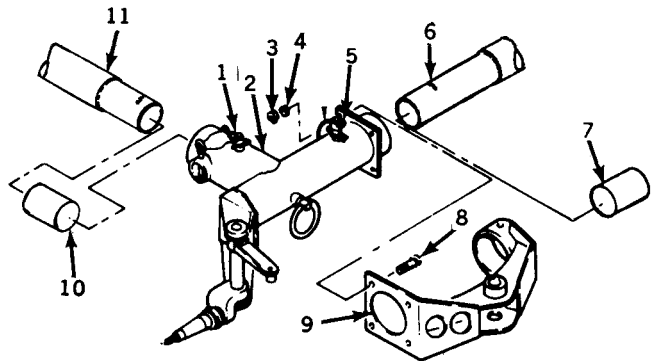

11. Place rubber boots (2) and (5) over left front corner assembly tubes. Fold back the boots.

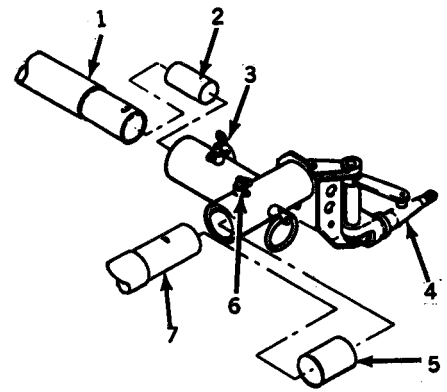

12. Slide front tube (7) into left front corner assembly (4). Align holes and push lockpin (6) in place.

13. Slide side tube (1) into left front corner assembly. Align holes and push lock pin (3) in place.

14. Place rubber boots (7) and (4) over left rear corner assembly tubes. Fold back boots.

15. Slide side tube (5) into left rear corner assembly (2). Align holes and push lock pin (3) in place.

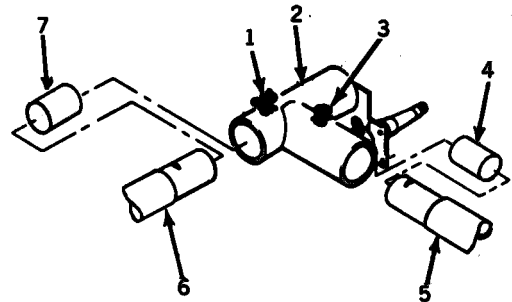

16. Slide rear tube (6) into left rear corner assembly. Align holes and push lock pin (1) in place.

17. Place rubber boots (1) and (4) over right rear corner assembly tubes. Fold back boots.

18. Slide rear tube (2) into right rear corner assembly (5). Align holes and push lock pin (7) in place.

19. Slide side tube (3) into right rear corner assembly. Align holes and push lock pin (6) in place.

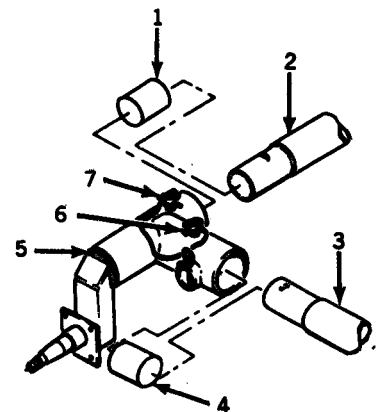

20. Unfold all eight rubber boots.

3-7. BOLSTERS ASSEMBLIES TO FRAME TUBES.

1. Place front bolster (1) over center of front frame tube (2).

2. Align holes and push bolster pin (4) in place.

3. Secure with tube locking cross pins (3).

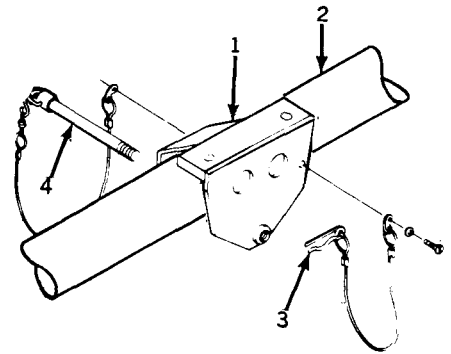

4. Place rear bolster with pintle hook (1) over rear frame tube (2).

5. Align holes and push bolster pin (3) through tube.

6. Secure with tube locking cross pin (4).

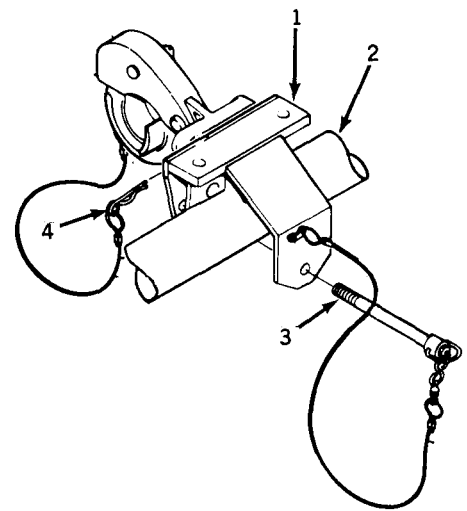

7. For each side bolster, place side bolster (2) over frame tube (1).

8. Align holes and push bolster pin (3) through holes.

9. Secure with tube locking cross pin (4).

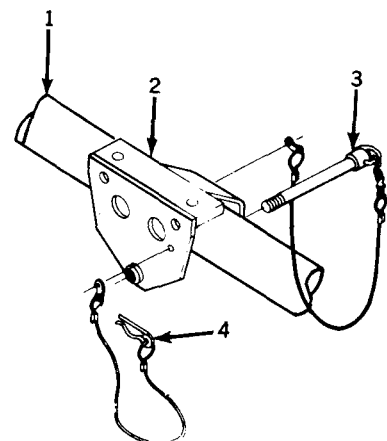

3-8. PALLET ASSEMBLY TO BOLSTERS.

1. Remove self-locking nuts, flat washers, bevel washers and capscrews from bolsters.

2. Position pallet to rest on bolsters. See that plug connector is forward.

3. Align holes in front bolster (2) with holes in pallet (1).

4. Push cap screws (3) in place from the bottom.

5. Place bevel washers (4) then flat washers (5) then start self locking nuts (6). Do not tighten.

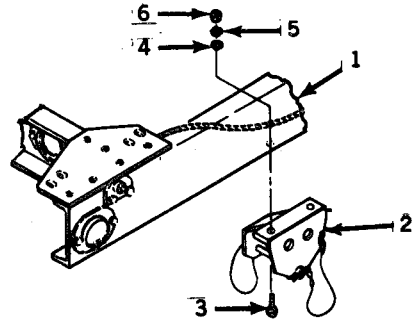

6. Align holes in left side bolster (6) with holes in pallet (1).

7. Push cap screws (5) in place from the bottom.

8. Place bevel washers (4) then flat washers (3), then start self-locking nuts (2). Do not tighten.

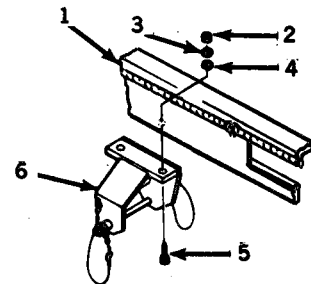

9. Align holes in rear bolster (6) with holes in pallet (1).

10. Push cap screws (5) in place from the bottom.

11. Place bevel washers (4), then flat washers (3), then start self locking nuts (2). Do not tighten.

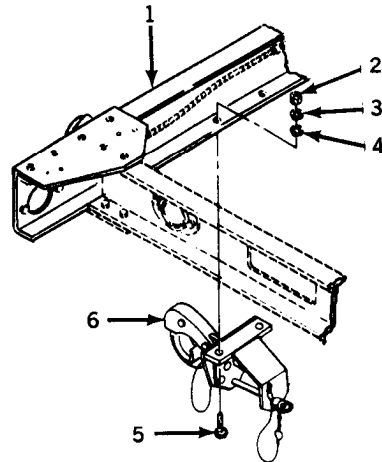

12. Align holes in right side bolster with holes in pallet (1).

13. Push cap screws (3) through holes from bottom of bolster (2).

14. Place bevel washers (4) then flat washers (5) then start self-locking nuts (6).

15. Tighten nuts on all bolsters.

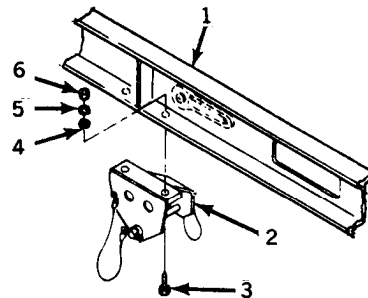

### 3-9. TONGUE TO FRAME.

1. Place tongue (5) in slot of tongue bracket (1). Align holes.

2. Slide pivot pin (3) into aligned holes. Be sure groove pin hole is at top and grease fitting hole is at bottom.

3. Align groove pin hole in pivot pin with groove pin hole in tongue bracket.

4. Drive groove pin (2) into aligned holes.

5. Screw lube fittings (4) into pivot pin.

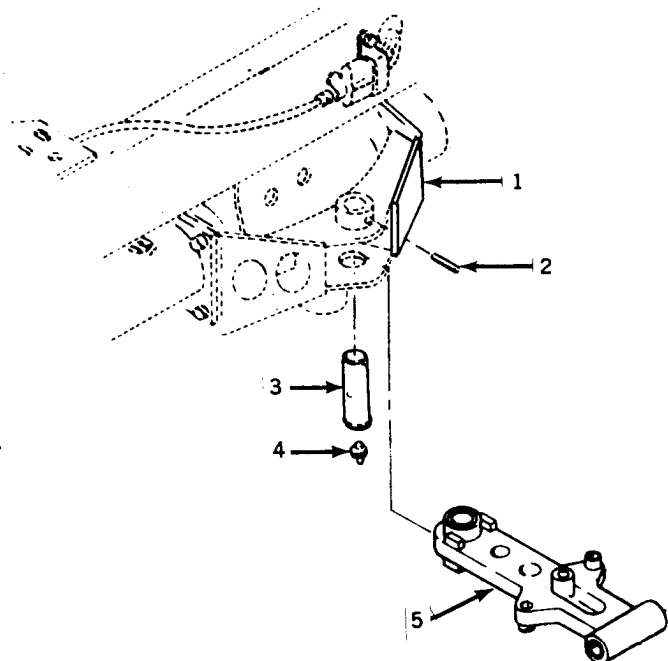



3-10. TIE RODS TO TONGUE AND CORNER ASSEMBLIES.

Left:

1. Place one end of the tie rod (3) under steering pivot (2).
2. Slide bolt (1) through steering pivot and tie rod. Secure with flatwasher (4), slotted nut (5) and cotter pin (6).
3. Place other end of tie rod under the hole at right side of the tongue bracket (7).
4. Push bolt (12) down through tongue bracket. Secure with flat washer (11), slotted nut (10) and cotter pin (9).
5. Screw lube fitting (8) into tongue bracket.

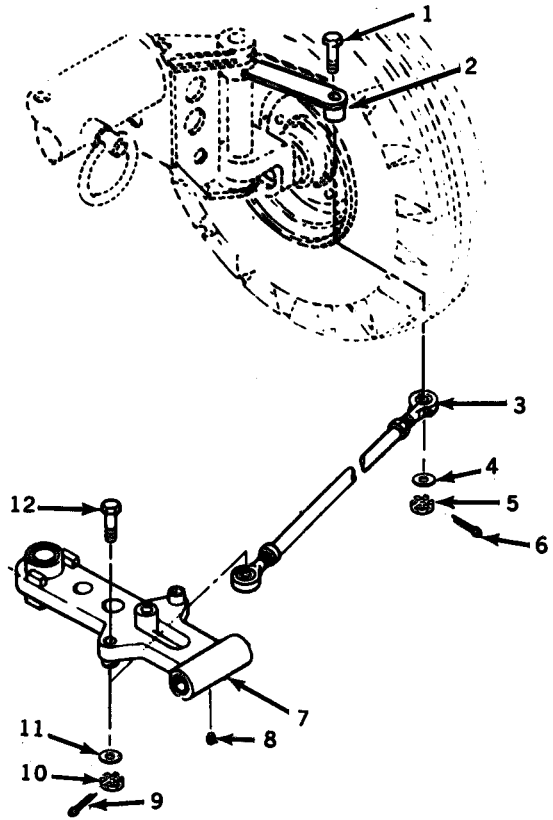

Right:

6. Place one end of other tie rod (3) under right side steering pivot (2).
7. Slide bolt (1) through pivot and tie rod and secure with washer (10) slotted nut (9) and cotter pin (8).
8. Place other end of tie rod over hole in left side of tongue.
9. Slide bolt (7) up through tongue and secure with washer (6) slotted nut (4) and cotter pin (5).

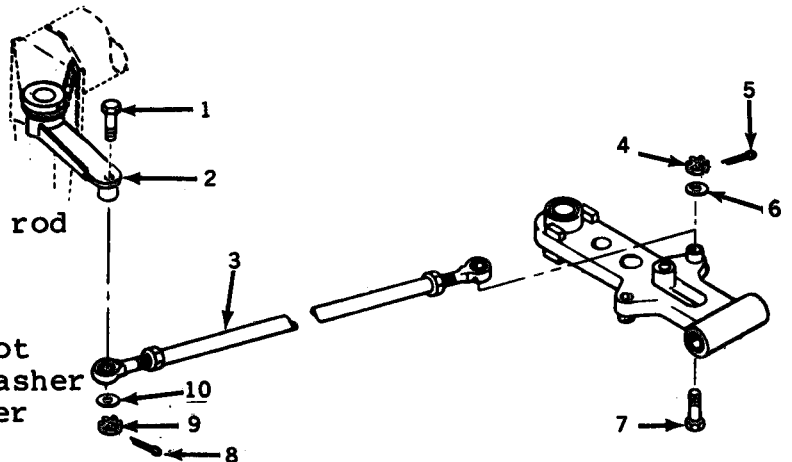

3-11. Towbar to tongue.

1. Remove cotter pin (4), slotted nut (5) and large bolt (2) from end of towbar (3).

2. Position tow bar (3) over tongue (1) and align holes.

3. Push bolt through towbar and tongue.

4. Secure bolt with the slotted nut (5) and cotter pin (4).

5. Attach electrical cable with gripper clip.

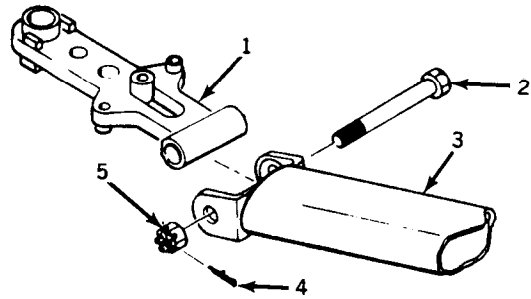

3-12. RAILS TO PALLET.

1. Pick a rail to use for the right side of the pallet.

2. Point the rail (3) so that the female coupler (4) is toward front. Female coupler has locking pin. Align holes (7) and (8).

3. Secure with cap screw (1), flat washers (2) and (6) and locknut (5).

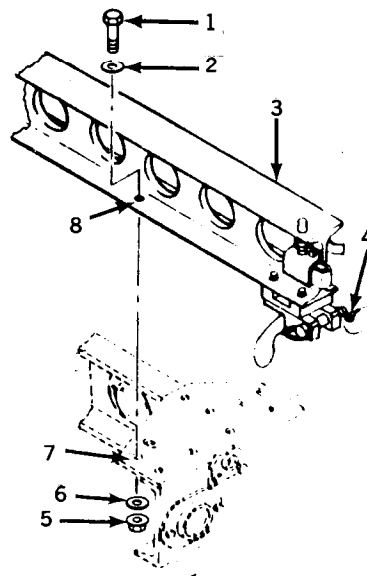

4. Align holes at rear of rails.

5. Secure with cap screws (1), flat washers (2) and (4) and locknuts (3).

6. Line up the other rail so that the male coupler is at the front of the left side of the trailer. Male coupler has no pin.

7. Line up with outer holes and secure with cap screws, washers and locknuts as before.

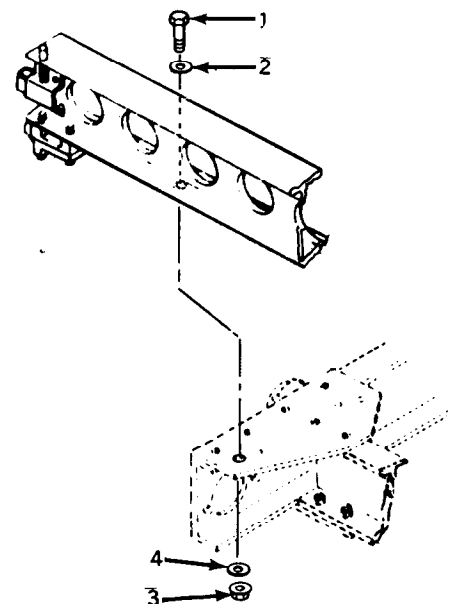

3-13. Jacks to frame tube.

1. Place jack (3) into pocket of frame tube (2).
2. Align holes in jack with holes in pocket of frame tube.
3. Secure with locking pin (1).
4. Repeat steps 1-3 for the rest of the jacks.

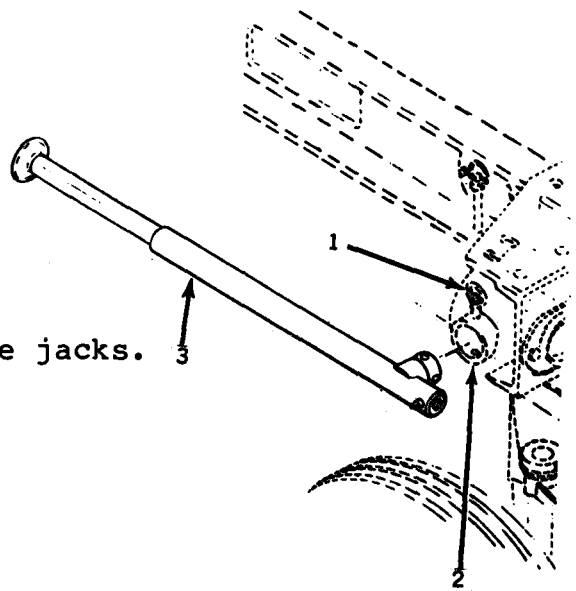

3-14. PRELIMINARY SERVICING OF EQUIPMENT. Before servicing, these checks and services must be done. See table 3-2.

Table 3-2. Preliminary Servicing of Equipment

ITEM	ACTION	REMARKS
Tires	Check pressure	Paragraph 3-15
Grease fittings	Lubricate	Paragraph 3-16
Wheel bearings	Adjust & lubricate	Paragraph 3-17
Tie rods	Adjust	Paragraph 3-18

3-15. TIRE PRESSURE. Recommended tire pressure is 60 psi.

3-16. LUBRICATION OF GREASE FITTINGS.

NOTE

Use automotive and artillery grease, MIL-G-10924.

a. Front bolster.

1 fitting at bolster pin

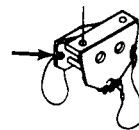

b. Side bolsters.

1 fitting at each bolster pin



c. Rear bolster

1 fitting at bolster pin

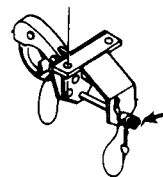

Corner Assemblies

d. Left front: 3 fittings.

- 1. at spindle
- 2. at frame tubes

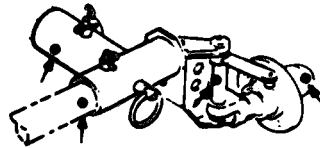

e. Left rear: 2 fittings at frame tubes.

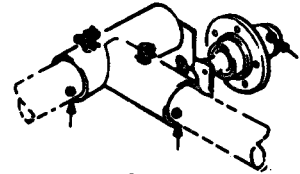

f. Right rear: 2 fittings at frame tubes.

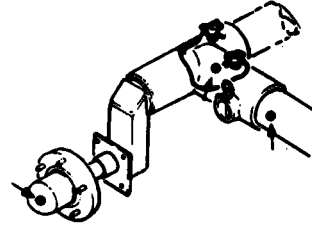

g. Right front: 3 fittings.

- 1 at spindle
- 2 at frame tubes

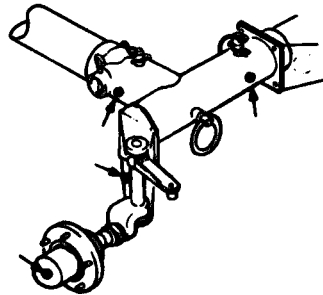

h. Jack: 1 fitting at top of each jack tube.

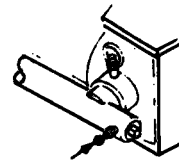

i. Steering: 7 fittings.

- 4 at tie rod ends
- 1 at frame tube (top)
- 1 at pivot pin (bottom)
- 1 at tow bar bolt (bottom)

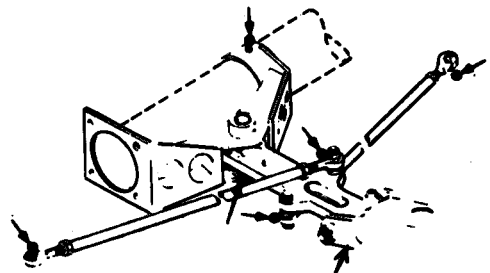

3-17. LUBRICATION AND ADJUSTMENT OF WHEEL BEARINGS.

1. Remove wheel, hub cap, cotter pin and slotted nut.
2. Remove hub. Inspect grease seal for defects. Inspect brake linings for signs of grease.
3. Repack bearings using automotive and artillery grease. Military Specification MIL-G-10924.
4. Replace hub. Secure with slotted nut.
5. Place wheel on hub. Secure with lug nuts.
6. Rotate wheel and tighten slotted nut until slight drag is felt. Back off slotted nut about 1/8 turn to nearest cotter pin slot.
7. Install cotter pin and hub cap.
8. Tighten lug nuts.

3-18. CHECKING AND ADJUSTING TIE RODS.

a. Checking.

1. Adjust wheel bearings. See para. 3-17. Place trailer on level floor or area.
2. Position tow bar straight ahead.
3. Measure between tread centers at hub height behind tires. (Measurement B)
4. Measure between tread centers at hub height in front of tires. (Measurement A)
5. Measurement A must be 1/16 inch less than measurement B.

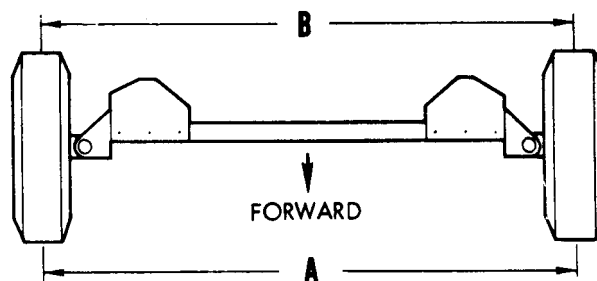

b. Adjusting. If measurement A is too short, lengthen tie rods. If measurement A is too long, shorten tie rods.

1. Loosen 2 locknuts (1) and (3) on both tie rods.
2. Turn tubes (2) to shorten or lengthen tie rods as needed.
3. Check adjustment.
4. When measurements are correct, tighten locknuts.

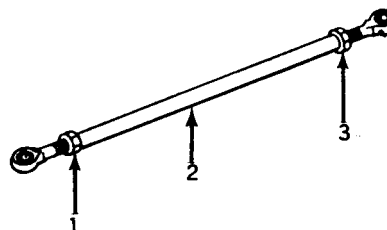

Section III. Preventive Maintenance Checks and Procedures (PMCS)

Table 3-3 AVUM PMCS

ITEM NO. COLUMN. Use this column to get item numbers to fill in TM number column on DA Form 2404, Equifient Inspection and Maintenance work sheet.

Interval Column.

ITEM No.	INTERVAL							ITEM TO BE INSPECTED	PROCEDURE
	D	W	M	Q	S	A			
1	•							Tires	Inflate to 60 psi.
2		•						Tires	Remove foreign matter. Inspect for tires that are defective or worn out. Replace as necessary. If tire wear is uneven, check wheel bearings and tie rod adjustment. (para. 3-17 and 3-18)
3		•						Wheel mounting hardware	Tighten lug nuts. Check slotted nuts on hubs for excessive play. Adjust as necessary.
4		•						Brake parts	Remove rear wheel assemblies and brake drums. Check for damage parts.
5				•				Brake linings	Remove rear wheel assemblies and brake drums. Check shoe linings.
6				•				Wheel bearings	Adjust wheel bearings (See para. 3-17)
7							•	Wheel bearings	Remove, clean, lubricate and adjust wheel bearings. Para. 3-17.

Table 3-3 AVUM PMCS (cont)

ITEM No.	INTERVAL						ITEM TO BE INSPECTED	PROCEDURE
	D	W	M	Q	S	A		
8					•		Tires	Rotate tires.
9			•					Check jack for looseness or binding.
10			•				Lube fittings	Lubricate all fittings. See para. 3-16.
11		•					All components	Tighten nuts and bolts. Replace parts with stripped or damaged threads.
12			•				Rubber boots	Replace loose or torn boots. See para 3-6.

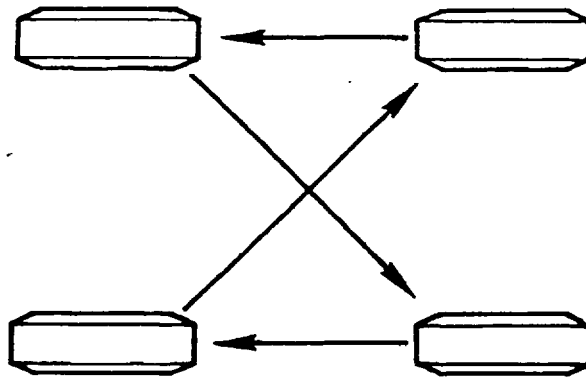



## Section IV. Troubleshooting

Table 3-4. Troubleshooting procedures

MALFUNCTION	INSPECTION OR TEST	CORRECTIVE ACTION
1. Uneven tire wear	Step 1. Wheel Alignment for 1/16 inch toe-in	Adjust (AVUM) (para. 3-17)
	Step 2. Wheel bearings for looseness	Adjust (AVUM) (para. 3-17)
2. Brakes not able to hold trailer	Step 1. Brake assembly for broken parts	Repair (AVIM) (para. 3-31)
	Step 2. Brake assembly for excessive lining wear	Repair (AVIM) (para. 3-31)
3. Noise from wheels	Step 1. Hub for wheel bearing adjustment	Adjust (AVUM) (para. 3-17)
	Step 2. Hub for broken parts	Repair (AVIM) (para. 3-26)
	Step 3. Brake assembly for broken parts	Repair (AVIM) (para. 3-31)
	Step 4. Defective wheel assembly	Replace wheel (AVIM) (para. 3-26)

Section V. Maintenance Procedures (AVUM and AVIM)

3-19. IDENTIFYING ASSEMBLIES FOR MAINTENANCE. For maintenance procedures, the trailer (figure 3-1) will be divided as shown in table 3-5.

Table 3-5. Trailer Assemblies

ASSEMBLY	INCLUDES	PARAGRAPH
Tow Bar	- tow bar, tongue, tie rods	3-20
Front Axle & Steering	- front corner assemblies king pins, spindles	3-25
Brake	- handles, drums, shoes	3-30
Rear Axle	- rear corner assemblies	3-32
Wheel	- tires, tubes, wheels, hubs, bearings	3-34
Rail	- rails, rail couplers	3-36
Pallet	- frame tubes, bolsters, pallet	3-39

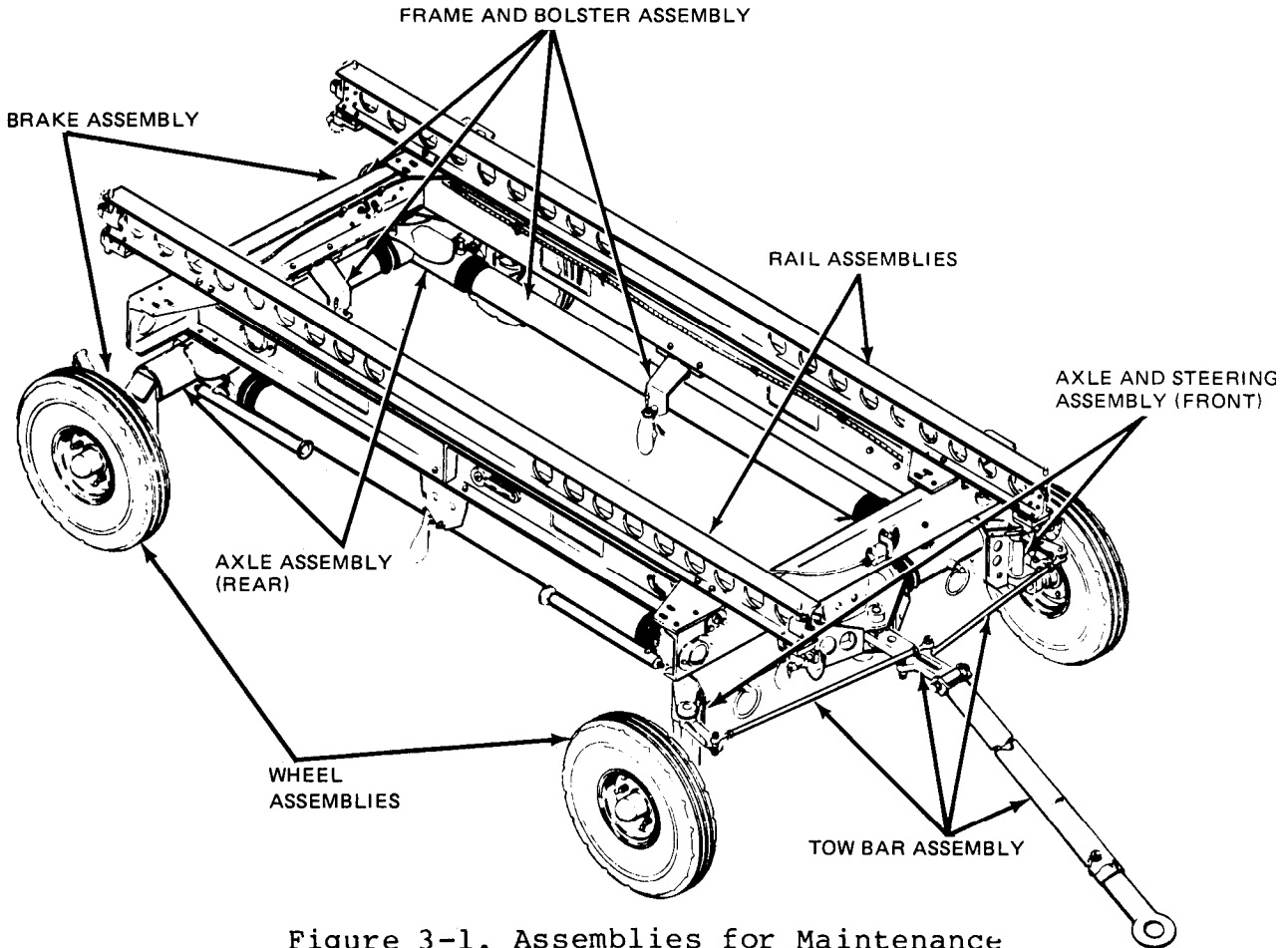

Figure 3-1. Assemblies for Maintenance

3-20. SUMMARY OF TOW BAR MAINTENANCE. Maintenance tasks are listed with, where-to-find detail procedures in table 3-6.

Table 3-6. Tow Bar Maintenance Checklist

TASK NUMBER	LIST OF TASKS	SEE PARAGRAPH
1	Inspect (AVUM)  Check for worn or damaged parts: Tie-rod ends, bushings at pivot pin and towbar bolt	
2	Bolt holes in tongue and towbar	
3	Bolts, nuts, washers, cotter pins  Replace: (AVUM)	
4	Remove attaching parts at tie rod ends	3-21
5	Remove pivot pin	3-22
6	Attach tongue assembly at pivot pin	3-9
7	Attach tie rod ends	3-10
8	Adjust  Repair: (AVIM) Perform tasks 4 and 5 then as needed remove and repair.	3-18
9	tie rod ends	
10	bushings  Perform tasks 6, 7, and 8 above	3-24

3-21. REMOVING TIE RODS.  
(AVUM)

a. Left.

1. Remove cotter pin (8)  
slotted nut (9) and washer (10).

2. Remove bolt (1) from  
steering pivot (11).

3. Remove cotter pin (4),  
slotted nut (3), and washer (5).

4. Remove bolt (6) from ton  
tongue (2) and tie rod (7).

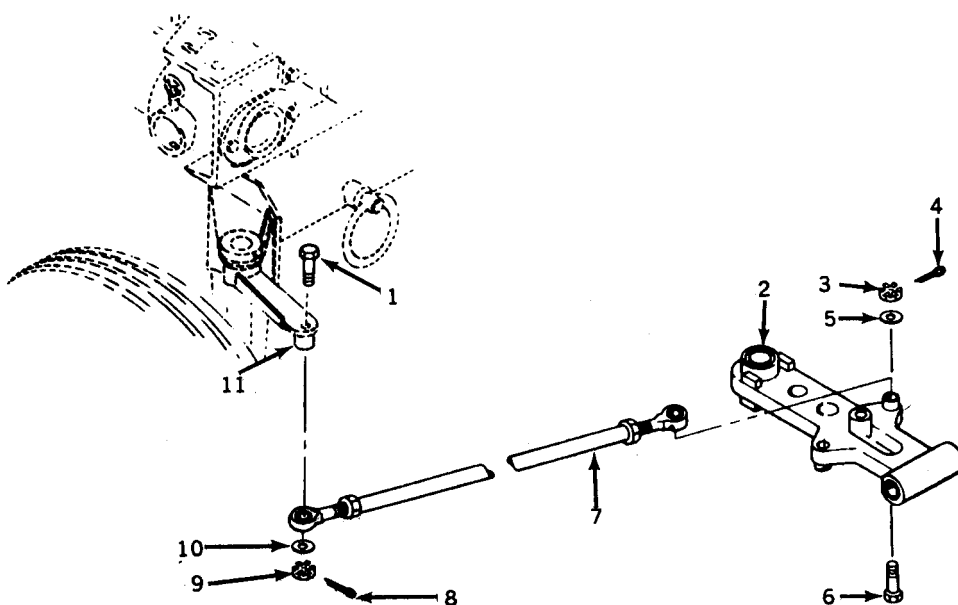

b. Right.

1. Remove cotter pin (8) slotted nut (9) and washers (10).

2. Remove bolt (1) from steering pivot (2).

3. Remove cotter pin (6) slotted nut (5) and washer (4).

4. Remove bolt (11) from tongue (7).

**NOTE**

See paragraph 3-10 to attach tie rods.

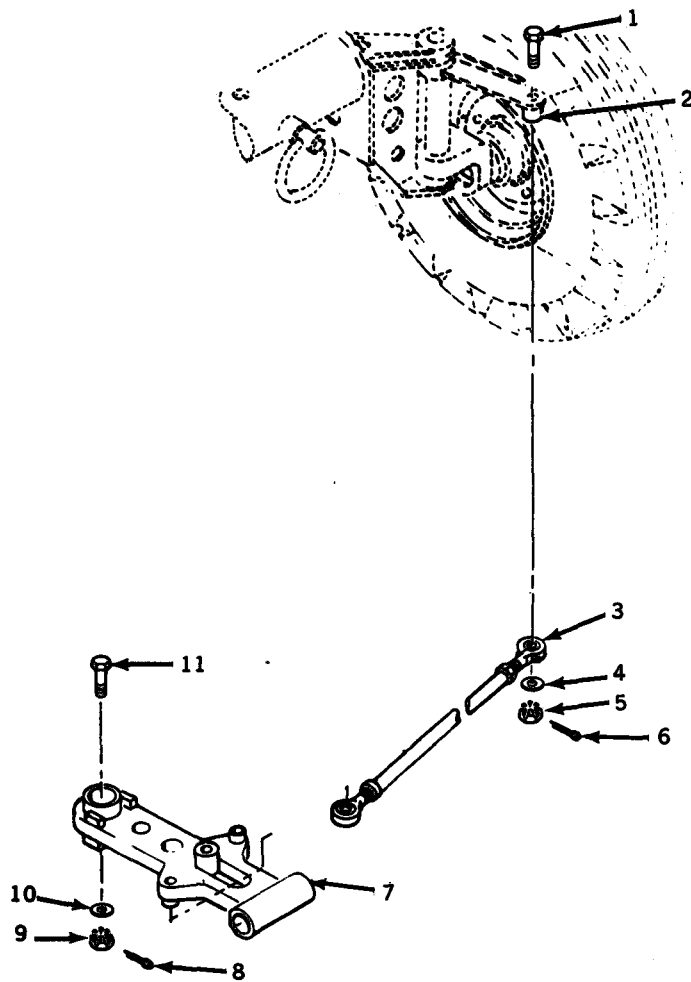

3-22. REMOVING PIVOT PIN. (AVUM)

1. Remove cotter pin (3), slotted nut (4) and long bolt (1) from tow bar (2).

2. Pull tow bar (2) back from tongue (5).

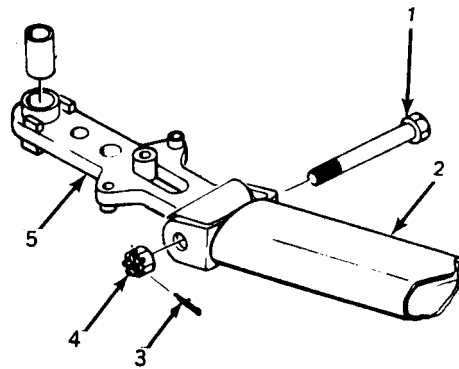

3. Drive groove pin (2) out of tongue bracket (1).

4. Remove pivot pin (3).

5. Pull back tongue (4) from tongue bracket (1).

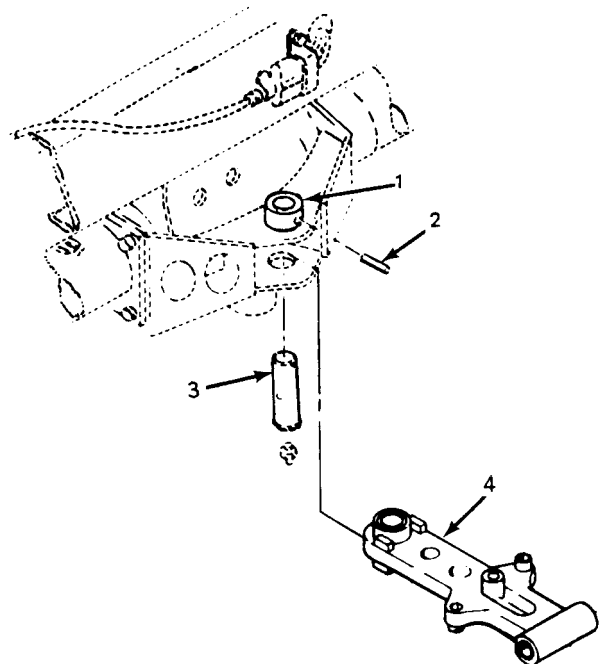

**NOTE**

See paragraphs 3-9 and 3-11 to attach tongue and tow bar.

3-23. REPAIR OF TIE ROD END. (AVIM).

1. Loosen locknuts (2 and 4).

2. Remove tie rod ends (1) and (5) from tie rod (3).

3. Remove locknuts (2) and (4) from tie rod ends (1) and (5).

4. Replace parts as needed.

5. Place locknuts (2) and (4) on tie rod ends (1) and (5).

6. Place tie rod ends (1) and (5) on tie rod (3).

7. Tighten locknuts.

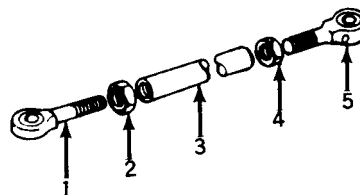

3-24. REPAIR OF BUSHINGS (AVIM).

1. Remove pivot pin bushing (1) from tongue (2).
2. Remove bushings (3) and (4) from front of tongue (2).
3. Replace with new parts as needed.
4. Replace pivot pin bushing (1) in rear of tongue (2) .
5. Replace bushings (3) and (4) in front of tongue.

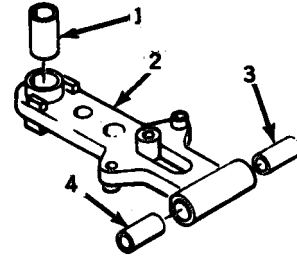

3-25. SUMMARY OF FRONT AXLE AND STEERING ASSEMBLY MAINTENANCE. See table 3-7.

Table 3-7. Axle and Steering Assembly (Front) Maintenance Checklist

TASK NUMBER	LIST OF TASKS	SEE PARAGRAPH
1	Inspect (AVUM)  Check for worn or damaged kingpins or bearings  Service (AVUM)	
2	Lubricate fittings at kingpins  Replace	3-16
3	Remove pallet assembly	2-6
4	Remove wheels and hubs	3-26
5	Remove corner assemblies	3-27
6	Attach corner assembly	3-6
7	Attach hubs and wheels	3-26
8	Attach pallet assembly	2-6
9	Adjust the tie rods	3-18
	Repair (AVIM)  Perform task 3, 4, and 5 above then as needed remove and repair.	

Table 3-7. Axle and Steering Assembly (front) Maintenance Checklist  
(cont)

TASK NUMBER	LIST OF TASKS	SEE PARAGRAPH
10	King pins	3-28
11	Spindle bearings	3-29

Perform tasks 6, 7, 8 and 9

3-26. REMOVING WHEELS AND HUBS  
(AVIM)

1. Loosen and remove lugnuts (7).
2. Remove wheel (6).
3. Remove hub cap (5), cotter pin (4) and slotted nut (3).
4. Remove hub (2) from spindle (1).
5. Reinstall good hub (2) on spindle (1).
6. Replace slotted nut (3).
7. Adjust wheel bearing (see paragraph 3-17).
8. Secure with slotted nut and cotter pin. Reinstall hub cap.

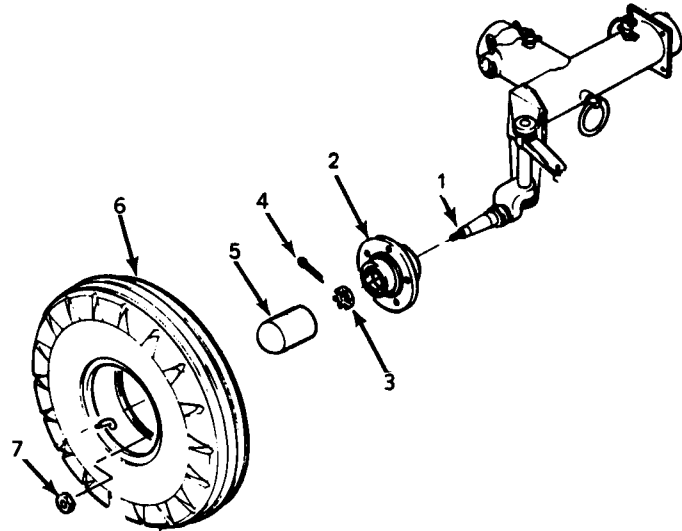

3-27. REMOVING FRONT CORNER ASSEMBLIES.

a. Right.

1. Support frame tubes (8) and (2).
2. Fold back rubber boots (7) and (3) onto corner assembly (6) tubes.
3. Loosen nuts (10). Remove washers (11) and bolts (5). Slide tongue bracket (4) back.
4. Remove rubber boots (3). Remove lock pins (9) and (1).
5. Pull corner assemblies back from frame tubes.

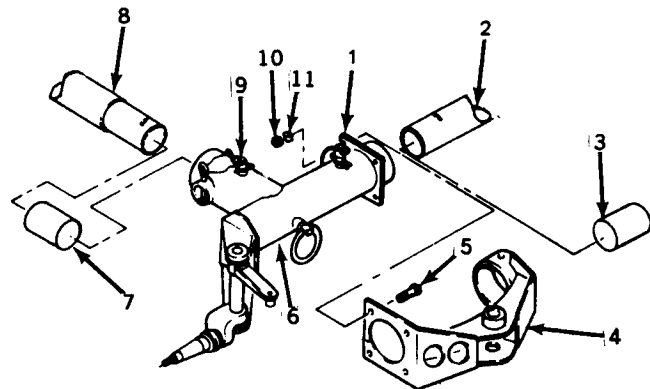



b. Left.

1. Support frame tubes (1) and (7).

2. Fold back rubber boots (2) and (6) onto corner assembly tubes.

3. Remove lockpins (3) and (4).

4. Pull corner assembly (5) back from frame tubes (1) and (7).

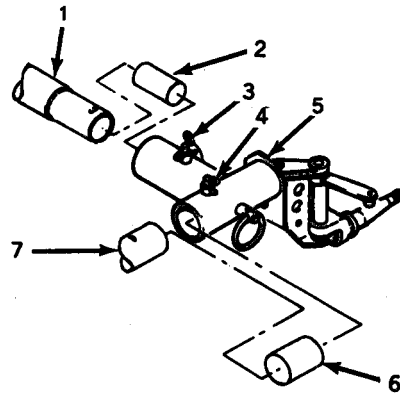

3-28. REMOVING AND INSTALLING KING-PINS (AVIM).

1. Drive spring pins (2) and (3) out of corner assembly (1).

2. Drive kingpin (4) out of holes.

3. Pull out spindle (6) and thrust washers (5) and (7).

4. Replace worn parts as needed.

5. Reinstall spindle (6) and thrust washers (5) and (7). Align holes.

6. Push kingpin (4) in place. Align spring pin holes.

7. Drive spring pins in place.

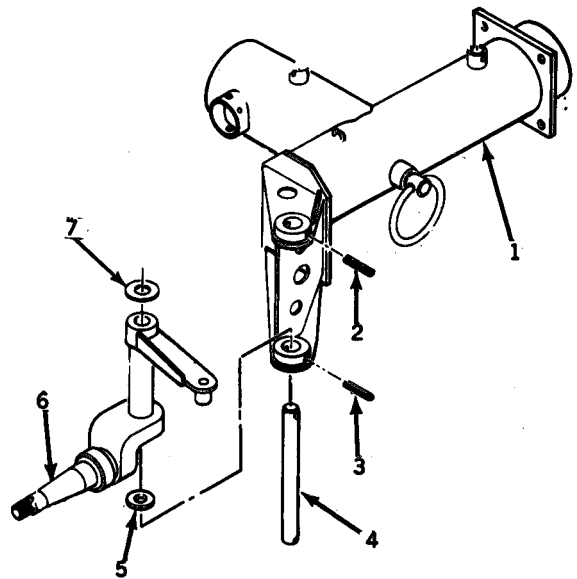

3-29. REMOVING SPINDLE BEARINGS (AVIM).

1. Remove spindle bearings (1) and (3) from spindle (2).

2. Replace worn parts as needed.

3. Reinstall bearings (1) and (3) in spindle.

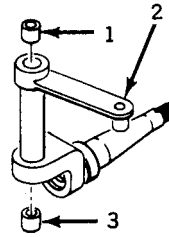

3-30. SUMMARY OF BRAKE MAINTENANCE. Maintenance tasks are listed with, where-to-find detail procedures. See table 3-8.

Table 3-8. Brake Maintenance Checklist

TASK NUMBER	LIST OF TASKS	SEE PARAGRAPH
1	Inspect (AVUM)	
2	Remove wheels and hubs (AVIM) Remove brake drums (AVIM)	3-26
3	Check drums, moving parts inside drums, linings (AVIM) Adjust (AVUM) Brakes are self adjusting Repair (AVIM) Perform tasks 1, 2, and 3 above then as needed, remove and repair.	
3	Remove and replace drums, linings, internal parts Replace (AVIM) Brake assembly Perform tasks 1, 2, and 3 above then, as needed, remove and repair	
4	Remove and replace brake assembly	3-31

3-31. REMOVING AND INSTALLING BRAKE ASSEMBLY (AVIM).

1. Remove wheel and hub (para. 3-26) .
2. Remove brake drum (5) from brake assembly (6).
3. Loosen nuts (2). Remove washers (3) and bolts (4).
4. Pull brake assembly (6) back from spindle (1).
5. Position new brake assembly (6) on spindle (1). Align holes.
6. Secure with bolts (4) washers (3) and nuts (2).
7. Reinstall brake drum.
8. Reinstall wheel and hub.

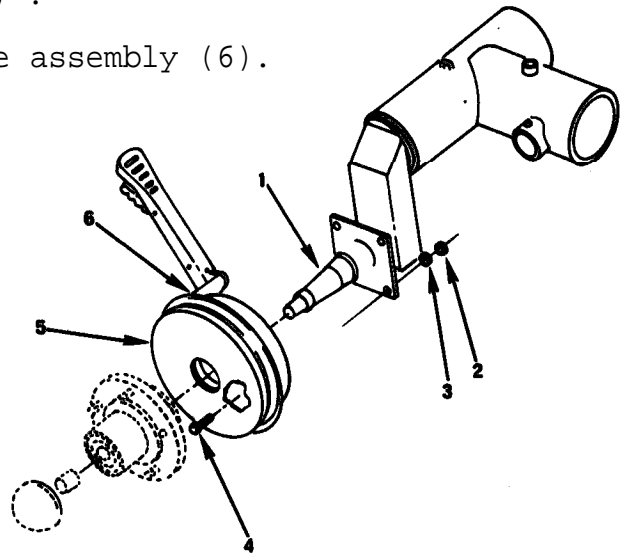

3-32. SUMMARY REAR AXLE MAINTENANCE. Maintenance tasks are listed with, where-to-find detail procedures in table 3-9.

Table 3-9. Rear Axle Maintenance Checklist

TASK NUMBER	LIST OF TASKS	SEE PARAGRAPH
	Inspect (AVUM)	
1	Check rear corner assembly for worn or damaged parts.	
	Service (AVUM)	
2	Lubricate fittings at frame tubes	3-16
	Replace (AVUM)	
	Perform task 1 above then as needed:	
3	Remove pallet assembly	2-6
4	Remove corner assembly	3-33
5	Install good corner assembly	3-33
6	Reinstall pallet assembly	2-6

Table 3-9. Rear Axle Maintenance Checklist (cont)

TASK NUMBER	LIST OF TASKS	SEE PARAGRAPH
	Repair (AVIM)	
	Perform tasks 1, 3, and 4 above then as needed, remove and repair	
7	Remove worn or damaged parts	
8	Install new parts	
	Perform task 5 and 6 above	

3-33. REMOVING AND INSTALLING REAR CORNER ASSEMBLIES (AVUM).

1. Fold back rubber boots (1) and (5) onto tubes of corner assembly (6).

2. Support frame tubes (2) and (4) so that corner assembly is clear of the ground.

3. Remove lock pins (7) and (3).

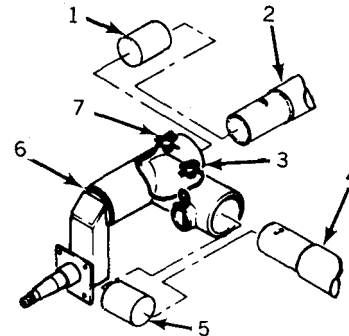

4. Pull corner assembly (6) back from frame tubes (2) and (4).

5. Place good corner assembly (6) on frame tubes (2) and (4).

6. Align holes and push lock pins in place.

7. Unfold rubber boots.

3-34. SUMMARY OF WHEEL ASSEMBLY MAINTENANCE. Maintenance tasks are listed with where-to-find detail procedures in table 3-10.

Table 3-10. Wheel Assembly Maintenance Checklist

TASK NUMBER	LIST OF TASKS	SEE PARAGRAPH
	Inspect (AVUM)	
1	Check tires for cuts, defects, wear, leaks	
2	Check wheel bearings for looseness, noise	
	Service (AVUM)	
3	Lubricate wheel bearings	3-17
4	Adjust wheel bearings	3-17
	Repair (AVIM)	
	Perform tasks 1 and 2 then as needed	
5	Remove wheel	3-26
6	Remove tube or tire. Reinstall tube or tire	3-35
7	Remove hub	3-26
8	Install new bearings in hub	
9	Reinstall hub	3-26
10	Reinstall wheel. Perform tasks 3 and 4	
	Replace (AVIM)	
	Perform tasks 1 and 2 then as needed:	
11	Replace wheel, install good wheel	3-26
12	Remove hub, install good hub	3-26
	Perform task 3 and 4	

3-35. REMOVING AND INSTALLING TIRE AND TUBE (AVUM).

1. Remove valve core to release air.
2. Remove nuts (5), lock washers (6), and bolts (1).
3. Separate inner wheel disk (4) from outer wheel disk (7).
4. Remove tube (2) from tire (3).
5. Place good tube stem thru outer disk (7). Place inner wheel disk (4) and align holes.
6. Secure discs with bolts (1), lock washers (6) and nuts (5).
7. Install valve, core.

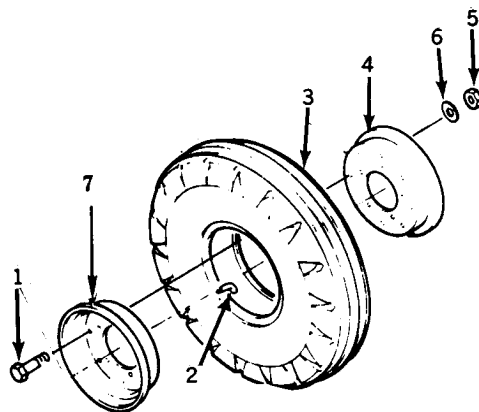

3-36. SUMMARY OF RAIL MAINTENANCE. Maintenance tasks are listed with, where-to-find detail procedures in table 3-11.

Table 3-11. Rail Assembly Maintenance Checklist

TASK NUMBER	LIST OF TASKS	SEE PARAGRAPH
	Inspect (AVUM)	
1	Check for loose or damage parts	
	Repair (AVUM)	
	Perform task 1 then as needed	
2	Remove rail couplers	3-37
3	Install good couplers	3-37
4	Remove rail stop assemblies	3-38
5	Install good rail stop assemblies	3-38
	Replace (AVIM)	
6	Remove rail assembly	
7	Install good rail assembly	3-12

3-37. REMOVING AND INSTALLING RAIL COUPLERS (AVIM).

1. Remove nuts (6), lock washers (5) and bolts (2).
2. Pull coupler (4) and spacer (3) away from rail (1).
3. Place good spacer and coupler under rail (1). Align holes.
4. Secure with bolts (2) lock washers (5) and nuts (6).

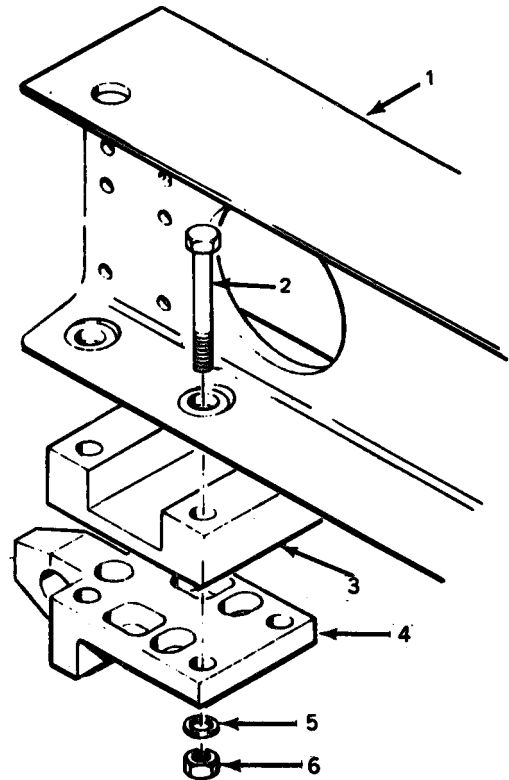

3-38. REMOVING AND INSTALLING RAIL STOPS (AVIM).

1. Remove nuts (4), lock washers (3) and bolts (9). Remove rail index clip (2).
2. Remove nut (5), lock washers (6) and bolts (8). Remove bad rail stop assembly (7).
3. Position good rail stop assembly (7). Align holes.
4. Secure with bolts (8) lock washers (6) and nut (5).
5. Position good rail index clip (2). Align holes.
6. Secure with bolts (9) lockwashers (3) and nuts (4).

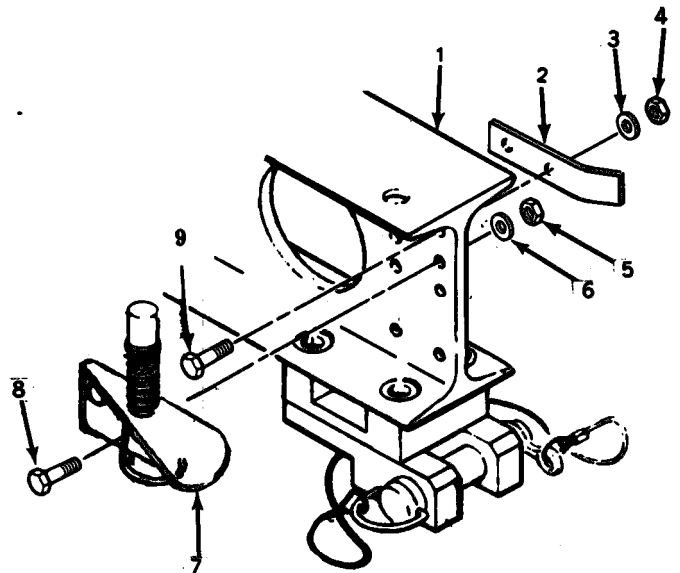

3-39. SUMMARY OF PALLET AND BOLSTER ASSEMBLY MAINTENANCE.  
 Maintenance task are listed with, where-to-find detail procedures.  
 See Table 3-12.

Table 3-12. Pallet and Bolster Maintenance Checklist

TASK NUMBER	LIST OF TASKS	SEE PARAGRAPH
	Inspect (AVUM)	
1	Check for loose or damaged pins	
2	Check lights in operation (Refer to figure 3-2 as necessary)	
	Replace (AVIM)	
	Perform tasks 1 and 2 then as needed	
3	Remove pallet assembly	2-6
4		2-6
	Repair (AVIM)	
	Perform tasks 1, 2, and 3 above then as needed	
5	Remove bolsters	3-40
6	Reinstall good bolsters	3-40

3-40. REMOVING AND INSTALLING BOLSTERS (AVIM).

1. Remove self-locking nut (1), flat washer (2), bevel washer (3) and bolt (5).

2. Pull bolster (4) away from frame. Repair as needed.

3. Position bolster (4) under frame. Align holes.

4. Push bolt (5) in place.

5. Secure with bevel washers (3), flat washer (2) and self-locking nut (1).

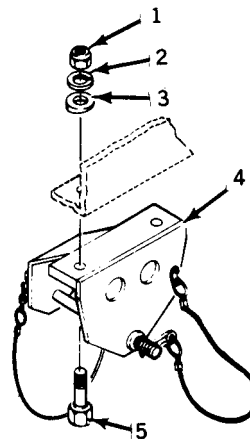



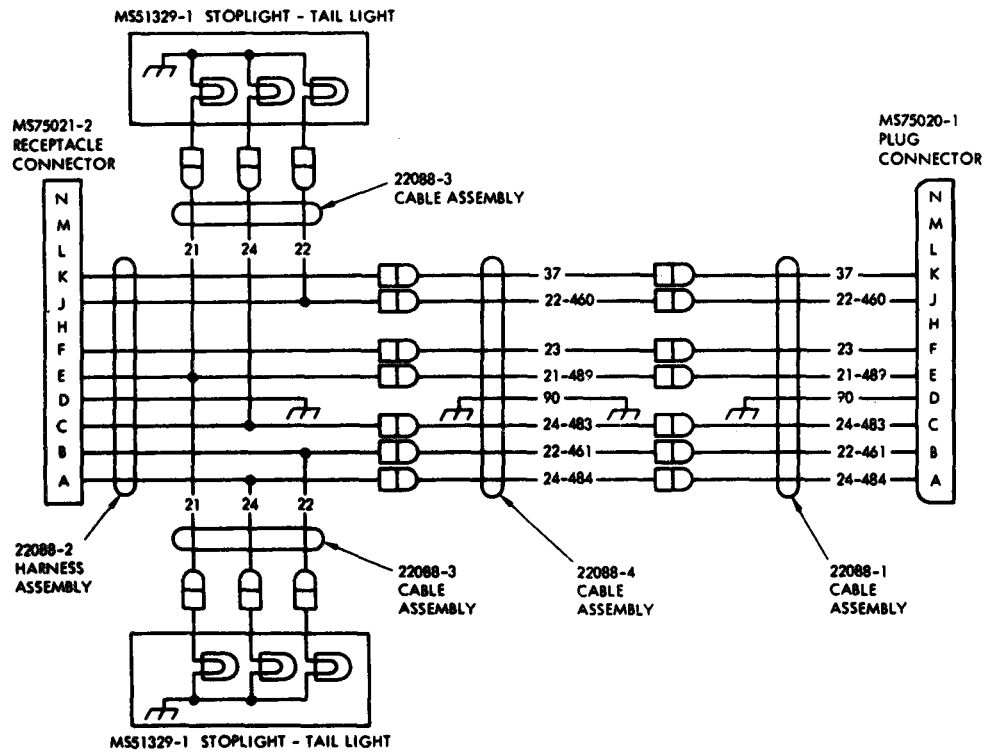

Figure 3-2. Wiring Diagrams

## APPENDIX A

### REFERENCES

A-1. Dictionaries of Terms and Abbreviations.

AR 310-25	Dictionary of United States Army Terms
AR 310-50	Authorized Abbreviations and Brevity Codes

A-2. Publication Index.

DA PAM 25-30	consolidated index of Army Publications and Blank Forms
--------------	---

A-3. Logistics and Storage.

TM 1-1500-204-23 (Series)	General Aircraft Maintenance Manual
TM 743-200-1	Storage and Materials Handling

A-4. Maintenance of Supplies and Equipment.

AR 750-1	Army Material Maintenance concepts and Policies
DA PAM 738-751	Functional Users Manual for The Army Maintenance Management System - Aviation (TAMMS-A)
TM9-213	Painting Instructions for Field Use

A-5. Other Publications.

TM 750-244-1-3	Procedures for the Destruction of Aviation Ground Sup-Equipment (FSC 1700) to Prevent Enemy use
AR 420-90	Fire Prevention and Protection

## APPENDIX B

## MAINTENANCE ALLOCATION CHART

## Section I. INTRODUCTION

## B-1. MAINTENANCE ALLOCATION CHART.

This Maintenance Allocation Chart (MAC) assigns maintenance functions in accordance with the Three Levels of Maintenance concept for army aircraft. These maintenance levels, Aviation Unit Maintenance (AVUM), Aviation Intermediate Maintenance (AVIM) and Depot Maintenance, are depicted on the MAC as:

AVUM which corresponds to the O code in the Repair Parts and Special Tools List (RPSTL).

AVIM which corresponds to the F code in the Repair Parts and Special Tools List (RPSTL).

DEPOT which corresponds to the D code in the Repair Parts and Special Tools List (RPSTL).

b. The maintenance to be performed below depot and in the field is described as follows:

(1) AVIATION UNIT MAINTENANCE (AVUM). AVUM activities will be staffed and equipped to perform high frequency "On-Equipment" maintenance tasks required to retain or return equipment to a serviceable condition. The maintenance capability of the AVUM will be governed by the MAC and limited by the amount and complexity of support equipment, facilities required, and number of spaces and critical skills available. The range and quantity of authorized spare modules/components will be consistent with the mobility requirements dictated by the air mobility concept. (Assignment of maintenance tasks to divisional company size aviation units will consider the overall maintenance capability of the division, the requirement to conserve personnel and equipment resources and air mobility requirements.)

(a) COMPANY SIZE AVIATION UNITS. Perform those tasks which consist primarily of preventive maintenance and maintenance repair and replacement functions associated with sustaining a high level of equipment operational readiness. Perform maintenance inspections and servicing to include daily, intermediate, periodic and special inspections as authorized by the MAC or higher headquarters. Identify the cause of equipment/system malfunctions using applicable technical manual troubleshooting instructions, Built-In Test Equipment (BITE), installed instruments, or easy to use Test Measurement and Diagnostic Equipment (TMDE). Replace worn or damaged modules/components which do not require complex adjustments or system alignment and which can be

removed/installed with available skills, tools and equipment. Perform operational and continuity checks and make minor repairs. Perform servicing, functional adjustments, and minor repair/replacement. Evacuate unserviceable modules/components and end items beyond the repair capability of AVUM to the supporting AVIM.

(b) LESS THAN COMPANY SIZE AVIATION UNITS. Aviation elements organic to brigade, group, battalion headquarters and detachment size units are normally small and have less than ten aircraft assigned. Maintenance tasks performed by the aircraft crew chief or assigned aircraft repairman will normally be limited to preventive maintenance, inspections, servicing, spot painting, stop drilling, minor adjustments, module/component fault diagnosis and replacement of selected modules/components. Repair functions will normally be accomplished by the supporting AVIM unit.

(2) AVIATION INTERMEDIATE MAINTENANCE (AVIM). AVIM provides mobile, responsive "One Stop" maintenance support. (Maintenance functions which are not conducive to sustaining air mobility will be assigned to depot maintenance.) Performs all maintenance functions authorized to be done at AVUM. Repair of equipment for return to user will emphasize support or operational readiness requirements. Authorized maintenance includes replacement and repair of modules/components and end items which can be accomplished efficiently with available skills, tools, and equipment. Establishes the Direct Exchange (DX) program for AVUM units by repairing selected items for return to stock when such repairs cannot be accomplished at the AVUM level. Inspects, troubleshoots, tests, diagnoses, repairs, adjusts, calibrates, and aligns system modules/components. Module component disassembly and repair will support the DX program and will normally be limited to tasks requiring cleaning and the replacement of seals, fittings and items of common hardware. Unserviceable repairable modules/components and end items which are beyond the capability of AVIM to repair will be evacuated to Depot Maintenance. This level will perform special inspections which exceed AVUM capability. Provides quick response maintenance support, on-the-job training, and technical assistance through the use of mobile maintenance contact teams. Maintains authorized operational readiness float. Provides collections and classification services for serviceable/unserviceable material. Operates a cannibalization activity in accordance with AR 750-50.

(The aircraft maintenance company within the maintenance battalion of a division will perform AVUM functions consistent with air mobility requirements and conservation of personnel and equipment resources. Additional intermediate maintenance support will be provided by the supporting non-divisional AVIM unit.)

## B-2. USE OF THE MAINTENANCE ALLOCATION CHART.

a. The MAC assigns maintenance functions to the lowest level of maintenance based on past experience and the following considerations:

- (1) Skills available.
- (2) Time required.
- (3) Tools and test equipment required and/or available.

b. Only the lowest level of maintenance authorized to perform a maintenance function is indicated. If the lowest level of maintenance cannot perform all tasks of any single maintenance function (e.g., test, repair), then the higher maintenance level(s) that can accomplish additional tasks will also be indicated.

c. A maintenance function assigned to a maintenance level will automatically be authorized to be performed at any higher maintenance level.

d. A maintenance function that cannot be performed at the assigned level of maintenance for any reason may be evacuated to the next higher maintenance organization. Higher maintenance levels will perform the maintenance functions of lower maintenance levels when required or directed by the appropriate commander.

e. The assignment of a maintenance function will not be construed as authorization to carry the associated repair parts in stock. Authority to requisition, stock, or otherwise secure necessary repair parts will be as specified in the repair parts and special tools list appendix.

f. Normally there will be no deviation from the assigned level of maintenance. In cases of operational necessity, maintenance functions assigned to a maintenance level may, on a one-time basis and at the request of the lower maintenance level, be specifically authorized by the maintenance officer of the level of maintenance to which the function is assigned. The special tools, equipment, etc., required by the lower level of maintenance to perform this function will be furnished by the maintenance level to which the function is assigned. This transfer of a maintenance function to a lower maintenance level does not relieve the higher maintenance level of the responsibility of the function. The higher level of maintenance has the authority to determine:

- (1) If the lower level is capable of performing the work.
- (2) If the lower level will require assistance or technical supervision and on-site inspection.
- (3) If the authorization will be granted,

g. Organizational through depot maintenance of the US Army Electronics Command equipment will be performed by designated US Army Electronics Command personnel.

h. Changes to the MAC will be based on continuing evaluation and analysis by responsible technical personnel and on reports received from field activities.

### B-3. DEFINITIONS.

a. INSPECT. To determine serviceability of an item by comparing its physical, mechanical and electrical characteristics with established standards.

b. TEST. To verify serviceability and detect incipient failure by measuring the mechanical or electrical characteristics of an item and comparing those characteristics with prescribed standards.

c. SERVICE. To clean, to preserve, to charge, and to add fuel, lubricants, cooling agents and air.

d. ADJUST. To rectify to the extent necessary to bring into proper operating range.

e. ALIGN. To adjust specified variable elements of an item to bring to optimum performance.

f. CALIBRATE. To determine the corrections to be made in the readings of instruments or test equipment used in precise measurement. Consists of the comparison of two instruments, one of which is a certified standard of known accuracy, to detect and adjust any discrepancy in the accuracy of the instrument or test equipment being compared with the certified standard.

g. INSTALL. To set up for use in an operational environment such as an emplacement, site or vehicle.

h. REPLACE. To replace unserviceable items with serviceable assemblies, subassemblies or parts.

i. REPAIR. To restore an item to serviceable condition through correction of a specific failure or unserviceable condition. This includes, but is not limited to, inspection, cleaning, preserving, adjusting, replacing, welding, riveting, and strengthening.

j. OVERHAUL. To restore an item to a completely serviceable condition as prescribed by maintenance serviceability standards prepared and published for the specific item to be overhauled.

k. REBUILD. To restore an item to a standard as nearly as possible to the original or new condition in appearance, performance and life expectancy. This is accomplished through the maintenance technique of complete disassembly of the item, inspection of all parts or components, repair or replacement of worn or unserviceable elements (items) using original manufacturing tolerances and specifications, and subsequent reassembly of the item.

B-4. FUNCTIONAL GROUPS. Standard functional groupings are not considered feasible for aviation ground support equipment due to variation and complexity. Therefore, variations to functional groupings may occur.

B-5. MAINTENANCE CATEGORIES AND WORK TIMES. The maintenance categories (levels) AVUM, AVIM, and DEPOT are listed on the Maintenance Allocation Chart with individual columns that indicate the work times for maintenance functions at each maintenance level. Work time

presentations such as 0.1 indicate the average time it requires a maintenance level to perform a specified maintenance function. If a work time has not been established, the columnar presentation shall indicate "-.-". Maintenance levels higher than the level of maintenance indicated are authorized to perform the indicated function.

B-6. TOOLS AND TEST EQUIPMENT (Section III). Common tool sets (not individual tools), special tools, test and support equipment required to perform maintenance functions are listed alphabetically with a reference number to permit cross-referencing to column 5 in the MAC. In addition, the maintenance category authorized to use the device is listed along with the item National Stock Number (NSN) and, if applicable, the tool number to aid in identifying the tool/device.

Section II. MAINTENANCE ALLOCATION CHART

NOMENCLATURE OF END ITEM

TRAILER AIRCRAFT MAINTENANCE AIRMOBILE  
 P/N 22142 TM 55-1730-224-13 & P NSN 1730-00-435-7818

(1)	(2)	(3)	(4)		(5)	(6)
GROUP NUMBER	COMPONENT/ASSEMBLY	MAINTENANCE FUNCTION	MAINTENANCE AVUM	MAINTENANCE AVIM	CATEGORY DEPOT	TOOLS AND REMARKS EQUIPMENT
00	TRAILER AIRCRAFT MAINTENANCE AIRMOBILE					
03	Chassis					
0301	Tow Bar Assy	Inspect Repair Replace	0.1  1.0	 1.0		117 102
0302	Axle & Steering Assy (Front)	Inspect Service Repair	0.2 0.3	 2.0		102
0303	Axle Assy (Rear)	Inspect Service Repair Replace	0.2 0.3  1.0	  2.0		102
0304	Brake Assy	Inspect Adjust Repair	0.2 1.0	 0.8		102
0305	Wheel Assy	Inspect Service Repair Replace	0.1 0.5	  0.5 1.0		102 102
0306	Rail Assy	Inspect Repair Replace	0.1 1.0	  2.0		102
0307	Frame and Bolster Assy	Inspect Service Repair	0.5 0.5	 1.0		102 102 117



(1) REFERENCE CODE	(2) MAINTENANCE CATEGORY	(3) NOMENCLATURE TOOL KIT, AIRCRAFT MECH- ANICS, GENERAL	(4) NATIONAL/NATO STOCK NUMBER 5180-00-323-4692
102	0		
117	F	SHOP SET, AVIM, SHEET METAL	4920-00-166-5505

## APPENDIX C

### REPAIR PARTS AND SPECIAL TOOLS LIST

#### SECTION I. INTRODUCTION

**C-1. Scope.** This RPSTL lists and authorizes spares and repair parts; special tools; special test, measurement, and diagnostic equipment (TMDE); and other special support equipment required for performance of Operator, Aviation Unit and Aviation Intermediate maintenance of the Trailer Aircraft Maintenance Airmobile. It authorizes the requisitioning, issue, and disposition of spares, repair parts and special tools as indicated by the source, maintenance and recoverability (SMR) codes.

**C-2. General.** In addition to Section I, Introduction, this Repair Parts and Special Tools List is divided into the following sections:

**a. Section II. Repair Parts List.** A list of spares and repair parts authorized by this RPSTL for use in the performance of maintenance. The list also includes parts which must be removed for replacement of the authorized parts. Parts lists are composed of functional groups in ascending alphanumeric sequence, with the parts in each group listed in ascending figure and item number sequence. Bulk materials are listed in item name sequence. Repair parts kits are listed separately in their own functional group within Section II. Repair parts for repairable special tools are also listed in this section. Items listed are shown on the associated illustration(s)/figure(s).

**b. Section III. Special Tools List.** A list of special tools, special TMDE, and other special support equipment authorized by this RPSTL (as indicated by Basis of Issue (BOI) information in DESCRIPTION AND USABLE ON CODE column) for the performance of maintenance. (Not applicable)

**c. Section IV. National Stock Number and Part Number Index.** A list, in National Item Identification Number (NIIN) sequence, of all National stock numbered items appearing in the listing, followed by a list in alphanumeric sequence of all part numbers appearing in the listings. National stock numbers and part numbers are cross-referenced to each illustration figure and item number appearance.

#### **C-3. Explanation of Columns (Sections II and III).**

**a. Item No. (Column (1)).** Indicates the number used to identify items called out in the illustration.

**b. SMR Code (Column (2)).** The Source, Maintenance, and Recoverability (SMR) code is a 5-position code containing supply/requisitioning information, maintenance category authorization criteria, and disposition instruction, as shown in the following breakout:

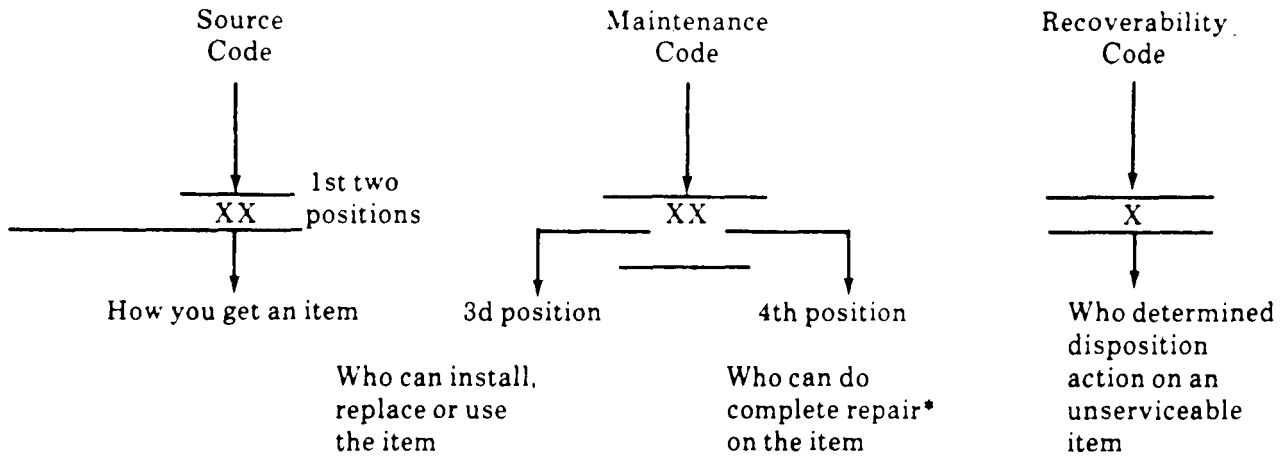

\*Complete Repair: Maintenance capacity, capability, and authority to perform all corrective maintenance tasks of the "Repair" function in a use-user environment in order to restore serviceability to a failed item.

(1) **Source Code.** The source code tells you how to get an item needed for maintenance, repair, or overhaul of an end item equipment. Explanations of source codes follows:

Code	Explanation
PA PB PC** PD PE PF PG	Stocked items; use the applicable NSN to request requisition items with the'se <b>source</b> codes. They are authorized to the category indicated by the code entered in the 3d position of the SMR code.  **NOTE: Items coded PC are subject to deterioration.
KD KF KB	Items with these codes are not to be requested requisitioned individually. They are part of a kit which is authorized to the maintenance category indicated in the 3d position of the SMR code. The complete kit must be requisitioned and applied.

Code	Explanation
MO- (Made at org AVUM Level) MF- (Made at DS AVUM Level) MH- (Made at GS Level) ML- (Made at Specialized Repair Act (SRA)) MD- (Made at Depot)	Items with these codes are not to be requested requisitioned individually. They must be made from bulk material which is identified by [he part number in the DESCRIPTION AND USABLE ON CODE (UOC) column and listed in the Bulk Material group of the repair parts list in this RPSTL. If the item is authorized to you by the 3d position code of the SMR code, but the source code indicates it is made at a higher level, order the item from the higher level of maintenance.

Code	Explanation
<p><b>AO-</b> (Assembled by org/ AVUM Level)  <b>AF-</b> (Assembled by DS/ AVIM Level)  <b>AH-</b> (Assembled by GS Category)  <b>AL-</b> (Assembled by SRA)  <b>AD-</b> (Assembled by Depot)</p>	<p>Items with these codes are not to be requested/requisitioned individually. The parts that make up the assembled item must be requisitioned or fabricated and assembled at the level of maintenance indicated by the source code. If the 3d position code of the SMR code authorizes you to replace the item, but the source code indicates the item is assembled at a higher level, order the item from the higher level of maintenance.</p>

- XA - Do not requisition an "XA"-coded item. Order its next higher assembly. (Also, refer to the NOTE below.)
- XB - If an "XB" item is not available from salvage, order it using the FSCM and part number given.
- XC - Installation drawing, diagram, instruction sheet, field service drawing, that is identified by manufacturer's part number.
- XD - Item is not stocked. Order an "XD" -coded item through normal supply channels using the FSCM and part number given, if no NSN is available.

NOTE: Cannibalization or controlled exchange, when authorized, may be used as a source of supply for items with the above source codes, except for those source coded "XA" or those aircraft support items restricted by requirements of AR 700-42.

(2) **Maintenance Code.** Maintenance codes tells you the level(s) of maintenance authorized to USE and REPAIR support items. The maintenance codes are entered in the third and fourth positions of the SMR Code as follows:

(a) The maintenance code entered in the third position tells you the lowest maintenance level authorized to remove, replace, and use an item. The maintenance code entered in the third position will indicate authorization to one of the following levels of maintenance.

Code	Application/Explanation
C	-Crew or operator maintenance done within organizational or aviation unit maintenance.
O	-Organizational or aviation unit category can remove, replace, and use the item.
F	-Direct support or aviation intermediate level can remove, replace, and use the item.
H	-General support level can remove, replace. and use the item.
L	-Specialized repair activity can remove, replace, and use the item.
D	-Depot level can remove, replace, and use the item.

(b) The maintenance code entered in the fourth position tells whether or not the item is to be repaired and identifies the lowest maintenance level with. the capability to do complete repair (i.e., perform all authorized repair functions.) (NOTE: Some limited repair may be done on the item at a lower level of maintenance, if authorized by the Maintenance Allocation Chart (MAC) and SMR codes ) This position will contain one of the following maintenance codes.

Code	Application Explanation
O	-Organizational or (aviation unit) is the lowest level that can do complete repair of the item.
F	-Direct support or aviation intermediate is the lowest level that can do complete repair of the item.
H	-General support is the lowest level that can do complete repair of the item.
L	-Specialized repair activity (designate the specialized repair activity) is the lowest level that can do complete repair of the item.
D	-Depot is the lowest level that can do complete repair of the item.
Z	-Nonreparable. No repair is authorized.
B	-No repair is authorized. (No parts or special tools are authorized for the maintenance of a "B" coded item). However, the item may be reconditioned by adjusting, lubricating, etc., at the user level.

(3) *Recoverability Code.* Recoverability codes are assigned to items to indicate the disposition action on unserviceable items. The recoverability code is entered in the fifth position of the SMR Code as follows:

Recoverability Codes	Application /Explanation
Z	-Nonreparable item, When unserviceable, condemn and dispose of the item at the level of maintenance shown in 3d position of SMR Code.
O	-Reparable item. When uneconomically repairable, condemn and dispose of the item at organizational or aviation unit level,
F	-Reparable item. When uneconomically repairable. condemn and dispose of the item at the direct support or aviation intermediate level.
H	-Reparable item. When uneconomically repairable, condemn and dispose of the item at the general support level,
D	-Reparable item, When beyond lower level repair capability, return to depot. Condemnation and disposal of item not authorized below depot level.
L	-Reparable item. Condemnation and disposal not authorized below specialized repair activity (SRA).
A	-Item requires special handling or condemnation procedures <b>because</b> of specific reasons (e.g., precious metal content, high dollar value, critical material, or hazardous material). Refer to appropriate manuals directives for specific instructions.

**c. FSCM (Column (3)).** The Federal Supply Code for Manufacturer (FSCM) is a 5-digit numeric code which is used to identify the manufacturer, distributor, or Government agency, etc., that supplies the item.

*d. Part Number (Column (4)).* Indicates the primary number used by the manufacturer (individual, company, firm, corporation, or Government activity), which controls the design and characteristics of the item by means of its engineering drawings, specification standards, and inspection requirements to identify an item or range of items.

NOTE: When you use a NSN to requisition an item, the item you receive may have a different part number from the part ordered.

*e. Description and Usable On Code (UOC) (Column (5)).* This column includes the following information:

(1) The Federal item name and, when required, a minimum description to identify the item.

(2) The physical security classification of the item is indicated by the parenthetical entry (insert applicable physical security classification abbreviation, e.g., Phy Sec C1 (C) - Confidential, Phy Sec C1 (S) - Secret, Phy Sec C1 (T) - Top Secret).

(3) Items that are included in kits and sets are listed below the name of the kit or set.

(4) Spare repair parts that make up an assembled item are listed immediately following the assembled item line entry.

(5) Part numbers for bulk materials are referenced in this column in the line item entry for the item to be manufactured fabricated.

(6) When the item is not used with all serial numbers of the same model, the effective serial numbers are shown on the last line(s) of the description (before UOC).

(7) The usable encode, when applicable (see paragraph 5. Special information).

(8) In the Special Tools List section, the basis of issue (BOI) appears as the last line(s) in the entry for each special tool, special TMDE, and other special support equipment. When density of equipments supported exceeds density spread indicated in the basis of issue, the total authorization is increased proportionately.

(9) The statement "END OF FIGURE" appears just below the last item description in Column 5 for a given figure in both Section II and Section III.

*f. QTY (Column (6)).* The QTY (quantity per figure column) indicates the quantity of the item used in the breakout shown on the illustration figure, which is prepared for a functional group, subfunctional group, or an assembly. A "V" appearing in this column in lieu of a quantity indicates that the quantity is variable and the quantity may vary from application to application.

#### **C-4. Explanation of Columns (Sect. IV).**

##### *a. National Stock Number (NSN) Index.*

(1) *Stock Number Column.* This column lists the NSN by National item identification number (NIIN) sequence. The NIIN consists of the last nine digits of the NSN (i.e.,  $\overbrace{5305-01-674-1467}^{\text{NSN}}$ ). When using this NIIN column to locate an item, ignore the first 4 digits of the NSN. However, the complete NSN should be used when ordering items by stock number.

(2) **Fig. Column.** This column lists the number of the figure where the item is identified/located. The figures are in numerical order in Section II and Section III.

(3) **Item Column.** The item number identifies the item associated with the figure listed in the adjacent FIG. column. This item is also identified by the NSN listed on the same line.

**b. Part Number Index.** Part numbers in this index are listed by part number in ascending alphanumeric sequence (i.e., vertical arrangement of letter and number combination which places the first letter or digit of each group in order A through Z, followed by the numbers 0 through 9 and each following letter or digit in like order).

(1) **FSCM Column.** The Federal Supply Code for Manufacturer (FSCM) is a 5-digit numeric code used to identify the manufacturer, distributor, or Government agency, etc., that supplies the item.

(2) **Part Number Column.** Indicates the primary number used by the manufacturer (individual, firm, corporation, or Government activity), which controls the design and characteristics of the item by means of its engineering drawings, specifications standards, and inspection requirements to identify an item or range of items.

(3) **Stock Number Column.** This column lists the NSN for the associated part number and manufacturer identified in the Part Number and FSCM Columns to the left.

(4) **FIG. Column.** This column lists the number of the figure where the item is identified located in Section II and III.

(5) **Item Column.** The item number is that number assigned to the item as it appears in the figure referenced in the adjacent figure number column.

**C-5. Special Information.** Use the following subparagraphs as applicable:

**a. Usable On Code.** The usable on code appears in the lower left corner of the Description column heading. Usable on codes are shown as "UOC: . . ." in the Description Column (justified left) on the first line applicable item description nomenclature. Uncoded items are applicable to all models. Identification of the usable on codes used in the RPSTL are:

Code

Used On

NOT APPLICABLE

**b. Fabrication Instructions.** Bulk materials required to manufacture items are listed in the Bulk Material Functional Group of this RPSTL. Part numbers for bulk materials are also referenced in the description column of the line item entry for the item to be manufactured fabricated. Detailed fabrication instructions for items source codes to be manufactured or fabricated are not applicable.

**c. Assembly Instructions.** Detailed assembly instructions for items source coded to be assembled from component spare/repair parts are not applicable. Items that make up the assembly are listed immediately following the assembly item entry or reference is made to an applicable figure.

**d. Kits.** Line item entries for repair parts kits appear in a group in Section II. (Not Applicable).

**e. Index Numbers.** Items which have the word BULK in the figure column will have an index number shown in the item number column. This index number is a cross-reference between the National Stock Number/Part Number Index and the bulk material list in Section II.

*f. Associated Publications.* The publication(s) listed below pertain to (insert applicable equipment nomenclature) and its components:

Publication	Short Title
-------------	-------------

NOT APPLICABLE

NOTE: Associated publications shall not be listed here in combined narrative and RPSTL manuals.

#### **C-6. How to Locate Repair Parts.**

##### *a. When National Stock Number or Part Number is Not Known.*

(1) *First.* Using the table of contents, determine the assembly group or subassembly group to which the item belongs. This is necessary since figures are prepared for assembly groups and subassembly groups, and listings are divided into the same groups.

(2) *Second.* Find the figure covering the assembly group or subassembly group to which the item belongs.

(3) *Third.* Identify the item on the figure and note the item number.

(4) *Fourth.* Refer to the Repair Parts List for the figure to find the part number for the item number noted on the figure.

(5) *Fifth.* Refer to the Part Number Index to find the NSN, if assigned.

##### *b. When National Stock Number or Part Number is Known:*

(1) *First.* Using the Index of National Stock Numbers and Part Numbers, find the pertinent National Stock Number or Part Number. The NSN index is in National Item Identification Number (NIIN) sequence (see C-4.1(1)). The part numbers in the Part Number index are listed in ascending alphanumeric sequence (see 4.b). Both indexes cross-reference you to the illustration figure and item number of the item you are looking for.

(2) *Second.* After finding the figure and item number, verify that the item is the one you're looking for, then locate the item number in the repair parts list for the figure.



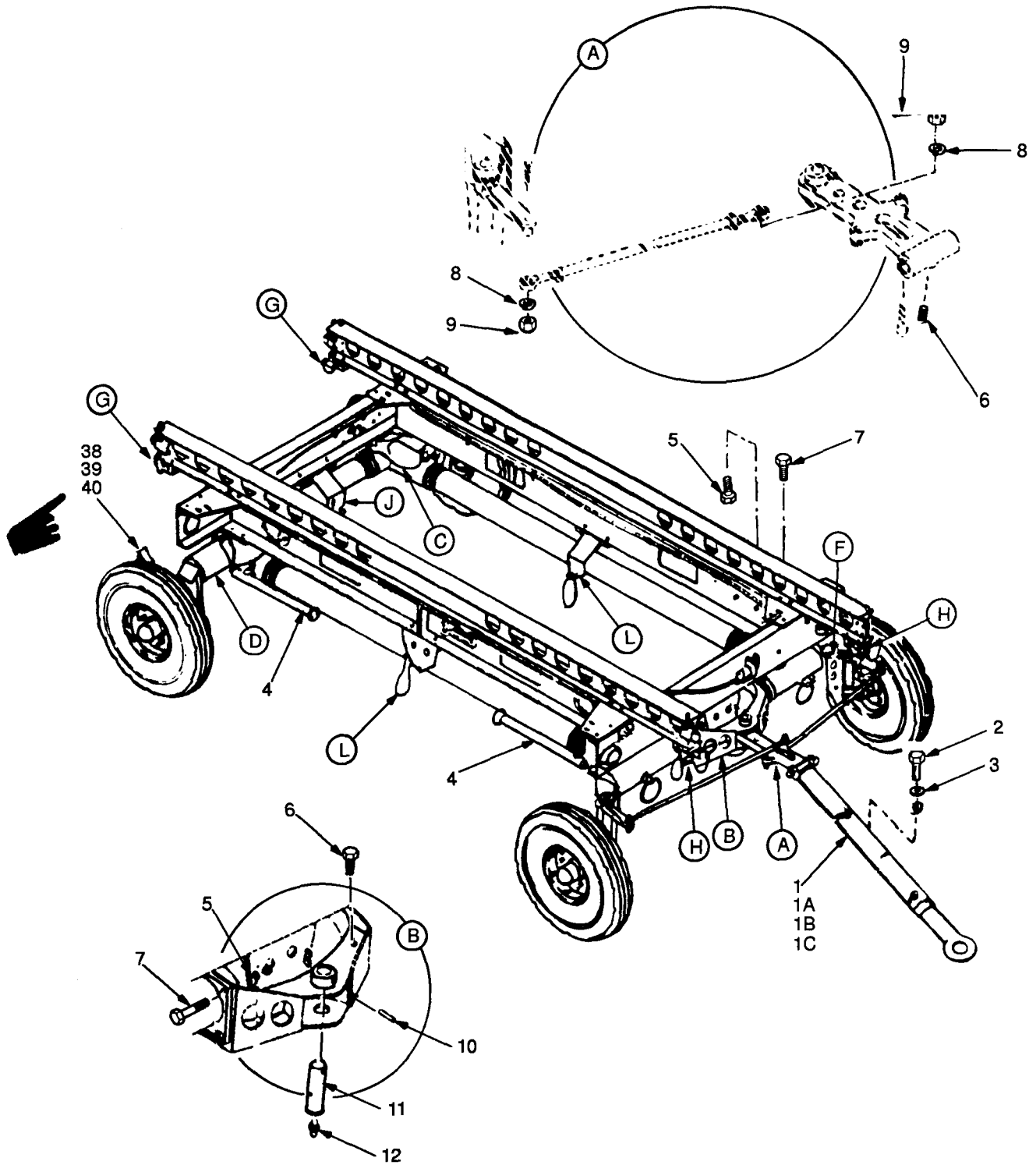

Figure C-1.. Maintenance Trailer (Sheet 1 of 6).

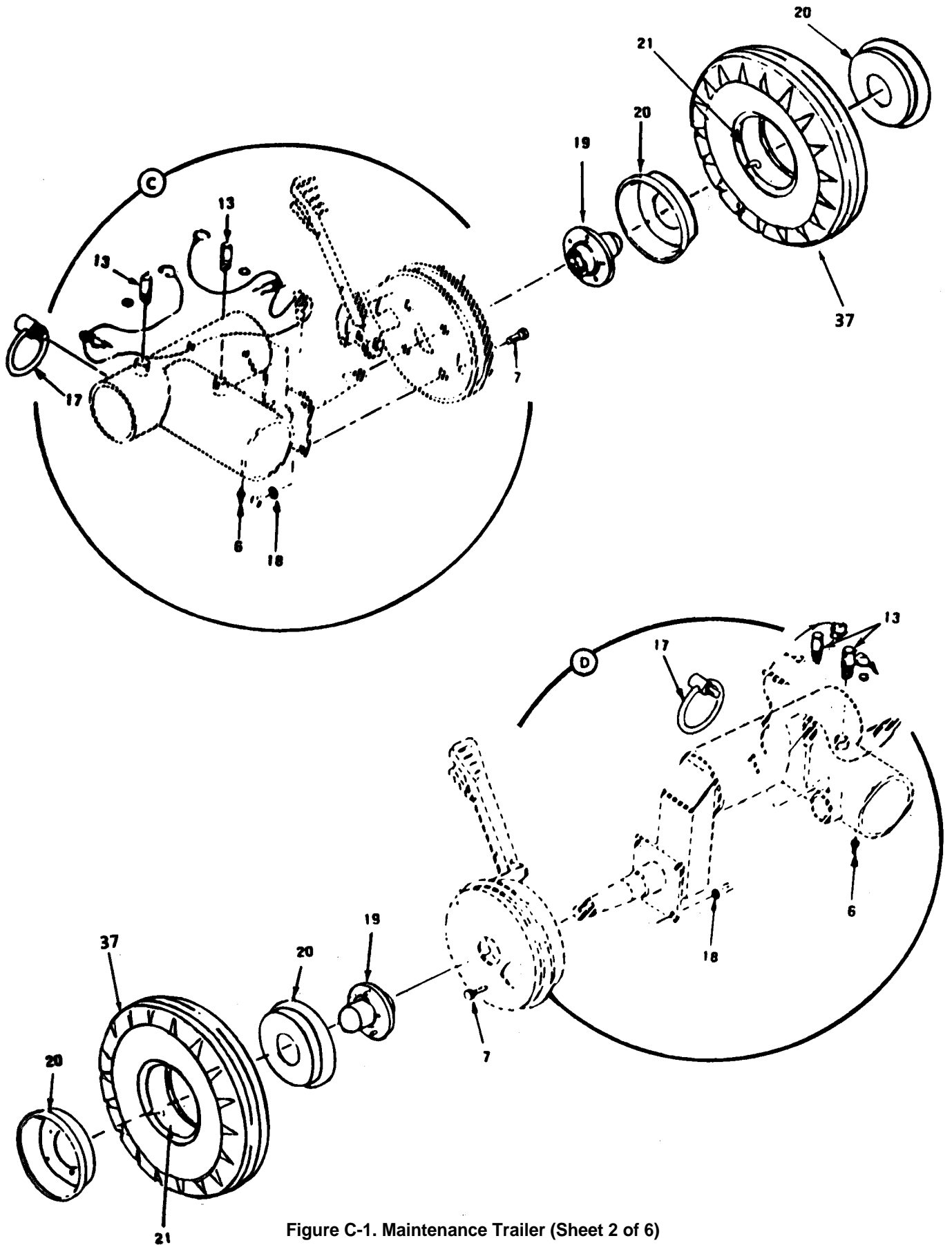

Figure C-1. Maintenance Trailer (Sheet 2 of 6)

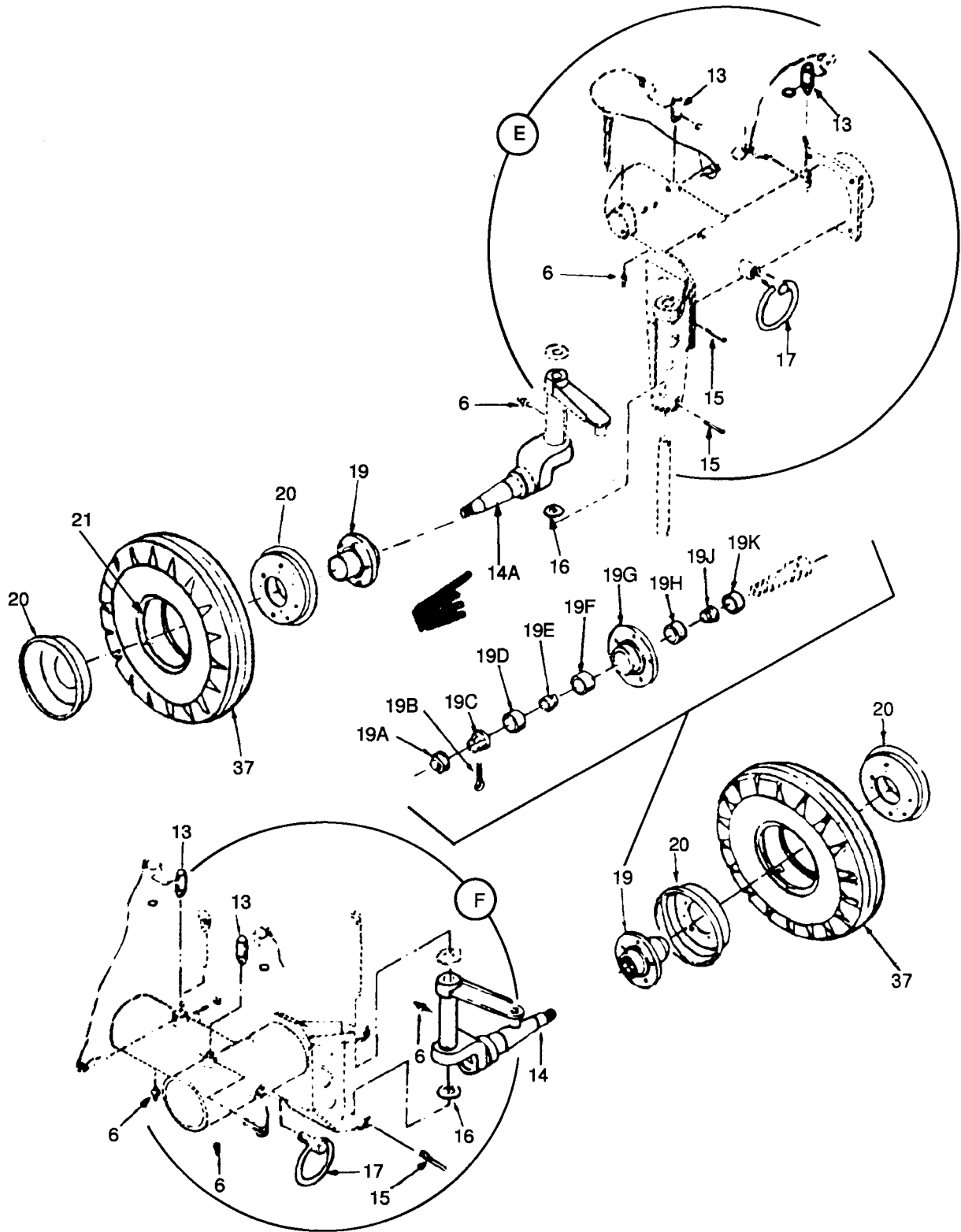

Figure C-1. Maintenance Trailer (Sheet 3 of 6).

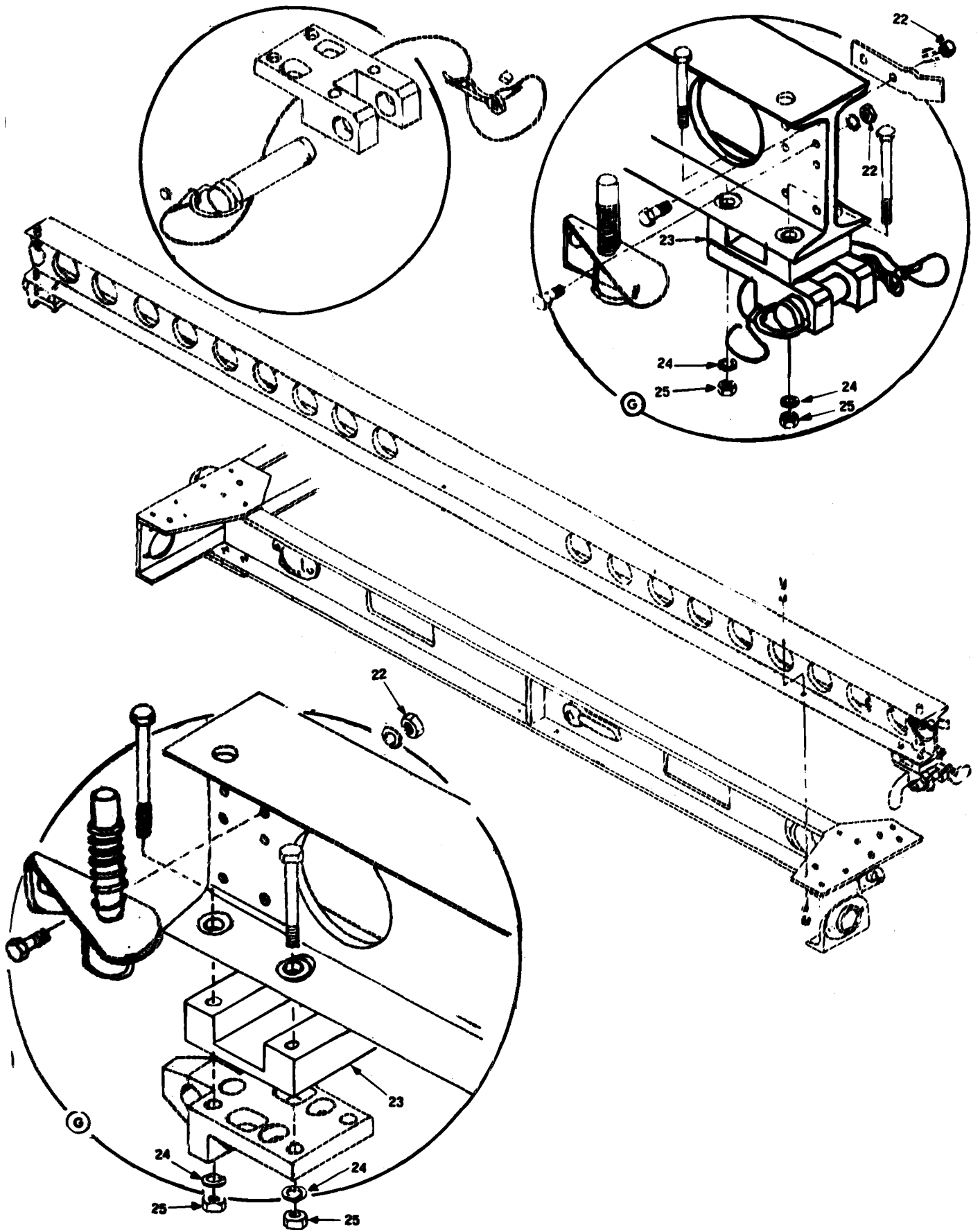
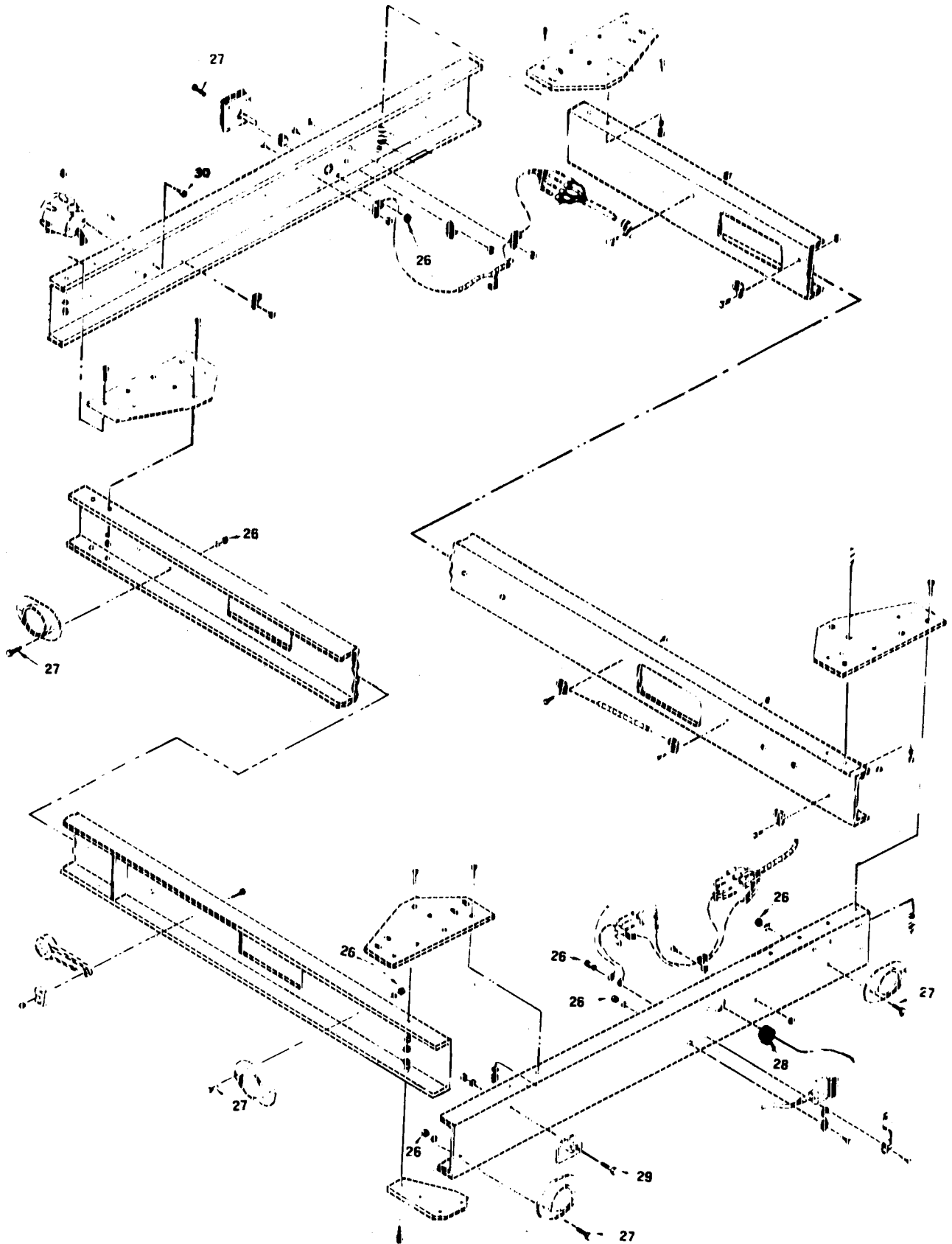

Figure C-1. Maintenance Trailer (Sheet 4 of 6)



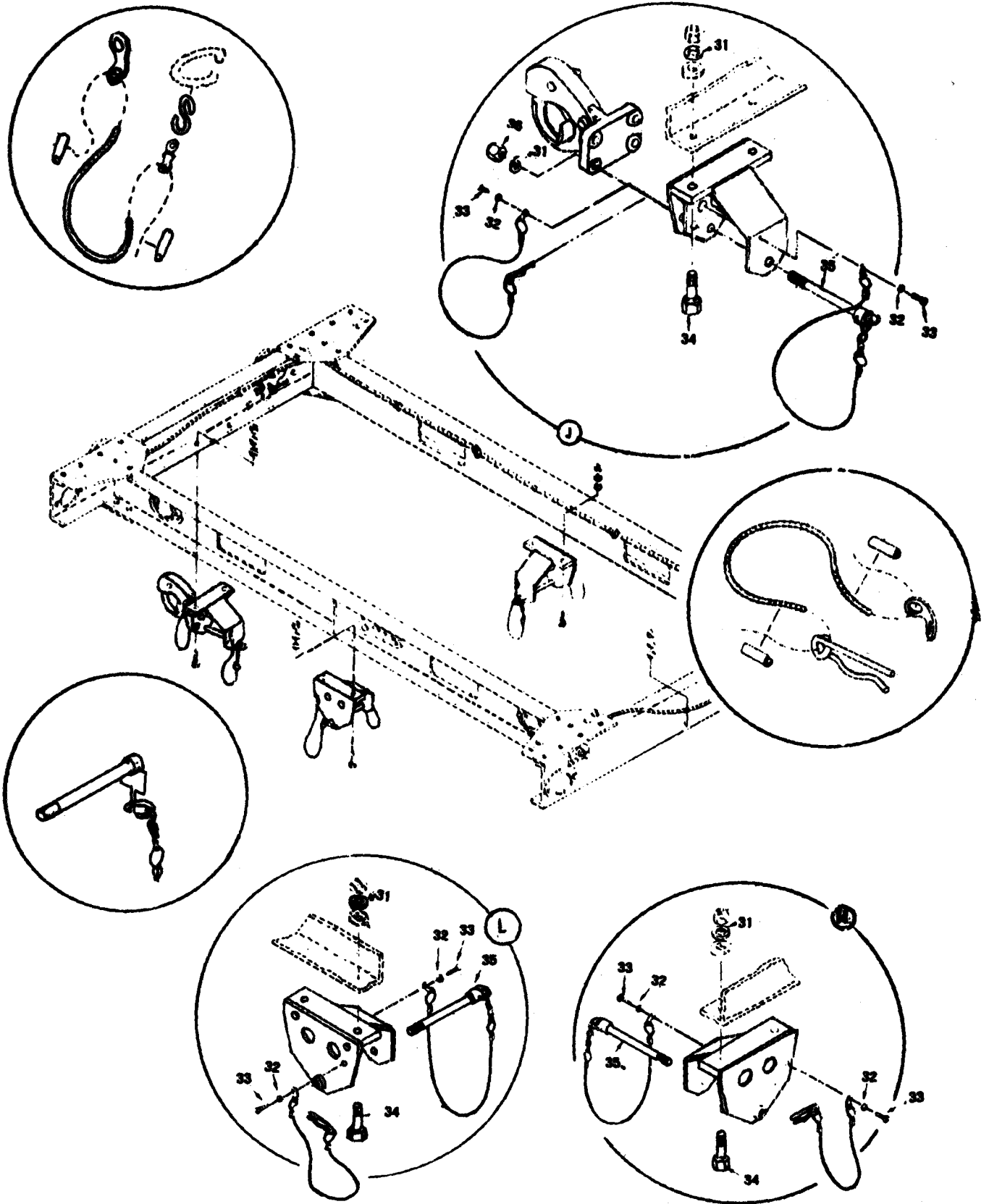

Figure C-1. Maintenance Trailer (Sheet 6 of 6)

(1) ITEM NO	(2) SMR CODE	(3) FSCM	(4) PART NUMBER	(5) DESCRIPTION AND USABLE ON CODE (UOC)	(6) QTY
GROUP 00. TRAILER AIRCRAFT MAINTENANCE AIRMOBILE					
FIGURE C1. MAINTENANCE TRAILER					
1	XBFFF	52793	22167	TOWBAR ASSEMBLY	1
1A	PBFZZ	96906	MS35692-1202	.NUT	1
1B	PBFZZ	96906	MS24665-423	.PIN,COTTER	1
1C	PBFZZ	88044	AN12-55	.BOLT	1
2	PBHZZ	96906	MS35206-261	.SCREW,MACHINE	1
3	PAOZZ	96906	MS35338-43	.WASHER,LOCK	1
4	XDFZZ	52793	38190	JACK ASSY	2
5	PBFZZ	96906	MS27183-14	WASHER,FLAT	24
6	PBOZZ	96906	MS15001-1	FITTING,LUBRICATION	11
7	PBOZZ	96906	MS90726-62	SCREW,CAP,HEXAGON H	8
8	PBFZZ	96906	MS27183-19	WASHER,FLAT	4
9	PAOZZ	96906	MS24665-287	PIN,COTTER	4
10	PBFZZ	96906	MS35671-41	PIN,GROOVED,HEADLES	1
11	XBFFZ	52793	38313	PIVOT PIN ASSY	5
12	PBOZZ	96906	MS15001-1	FITTING,LUBRICATION	1
13	XBFFZ	52793	22063	TUBE LOCKING PIN	8
14	XBFFZ	52793	38297-1	SPINDLE KING PIN AS	1
14A	XDFZZ	52793	38297-2	SPINDLE, KING PIN ASSY	1
15	PBFZZ	96906	MS39086-174	PIN,SPRING	4
16	PBFZZ	96906	MS27183-25	WASHER,FLAT	14
17	XBFFZ	98750	4887385	RING,CARGO TIEDOWN	4
18	PAOZZ	96906	MS35338-46	WASHER,LOCK	15
19	PBFFZ	96906	MS24328-2	HUB,WHEEL	4
19A	XDFZZ	52793	03-006394	.CAP,HUB	1
19B	PAFZZ	96906	AN380-4-7	.PIN,COTTER	1
19C	XDFZZ	96906	AN320-16	.NUT,SLOTTED HEX	1
19D	XDFZZ	81996	4920-EG-086-3	.WASHER	1
19E	PAFZZ	60038	15123	.CONE AND ROLLERS, TA	1
19F	PAFZZ	60038	15245	.CUP,TAPERED ROLLER	1
19G	XDFZZ	52793	03-006404-M	.HUB	1
19H	PAFZZ	60038	24720	.CUP,TAPERED ROLLER	1
19J	PAFZZ	60038	24780	.CONE AND ROLLERS, TA	1
19K	PAFZZ	52793	03-013021	.SEAL,GREASE	1
20	PBFZZ	96906	MS24325-2	WHEEL, PNEUMATIC	4
21	PBOZF	73808	6-00X9	INNER TUBE,PNEUMATI	4
22	PAFZZ	96906	MS51968-2	NUT,PLAIN,HEXAGON	1
23	XBFFZ	52793	22011	SPACER	4
24	PBFZZ	96906	MS35338-65	WASHER,LOCK	8
25	PBOZZ	96906	MS51968-8	NUT,PLAIN,HEXAGON	16
26	XDFZZ	96906	MS51967-2	NUT,PLAIN,HEXAGON	24
27	PBFZZ	96906	MS35206-280	SCREW,MACHINE	20
28	PBFZZ	96906	MS35489-81	GROMMET,NONMETALLIC	1
29	PBOZZ	96906	MS90726-60	SCREW,CAP,HEXAGON H	8
30	XDOZZ	96906	MS90725-59	SCREW,CAP,HEXAGON H	4
31	PBFZZ	96906	MS27183-18	WASHER,FLAT	12

## SECTION II

TM55-1730-224-13&amp;P

(1) ITEM NO	(2) SMR CODE	(3) FSCM	(4) PART NUMBER	(5) DESCRIPTION AND USABLE ON CODE (UOC)	(6) QTY
32	PBFZZ	96906	MS35338-41	WASHER, LOCK	8
33	PBOZZ	96906	MS35206-25	SCREW, MACHINE	8
34	PBFZZ	96906	MS90726-115	SCREW, CAP, HEXAGON H	8
35	XBFZZ	52793	38284	BOLSTER PIN ASSY	1
36	PAFZZ	96906	MS51968-14	NUT, PLAIN, HEXAGON	4
37	PBOZZ	96906	MS35389-6	TIRE, PNEUMATIC	4
38	XDFZZ	81996	4920-EG-092-1	BRAKE ASSY, RIGHT HAND	1
39	XDFZZ	81996	4920-EG-092-2	BRAKE ASSY, LEFT HAND	1
40	XDFZZ	81996	4920-EG-092-3	PEDAL, PARKING BRAKE	1

END OF FIGURE



## NATIONAL STOCK NUMBER AND PART NUMBER INDEX

## NATIONAL STOCK NUMBER INDEX

STOCK NUMBER	FIG	ITEM	STOCK NUMBER	FIG	ITEM
2610-00-050-9840	C-1	37			
5310-00-011-5093	C1	24			
5315-00-011-9120	C1	9			
5310-00-045-3296	C1	3			
5310-00-045-4007	C1	32			
4730-00-050-4203	C1	6			
	C1	12			
5310-00-080-6004	C1	5			
2610-00-089-5997	C1	21			
3110-00-100-0542	C1	19H			
3110-00-100-3537	C1	19J			
3110-00-198-2169	C1	19E			
3110-00-198-2170	C1	19F			
5305-00-226-7768	C1	34			
5305-00-269-2803	C1	29			
5305-00-269-2805	C1	7			
5325-00-270-8889	C1	28			
5315-00-290-9244	C1	10			
5310-00-637-9541	C1	18			
2530-00-646-7705	C1	19			
5310-00-732-0559	C1	25			
5310-00-732-0560	C1	36			
5310-00-768-0319	C1	22			
2530-00-801-2736	C1	20			
5310-00-809-3079	C1	8			
5310-00-809-5998	C1	31			
5310-00-809-8540	C1	16			
5315-00-882-0904	C1	15			
5305-00-984-4988	C1	33			
5305-00-984-6208	C1	2			
5305-00-988-1724	C1	27			

CHANGE 2

## NATIONAL STOCK NUMBER AND PART NUMBER INDEX

## PART NUMBER INDEX

FSCM	PART NUMBER	STOCK NUMBER	FIG	ITEM
88044	AN12-55		C1	1C
96906	AN320-16		C1	19C
96906	AN380-4-7		C1	19B
96906	MS15001-1	4730-00-050-4203	C1	6
			C1	12
96906	MS24325-2	2530-00-801-2736	C1	20
96906	MS24328-2	2530-00-646-7705	C1	19
96906	MS24665-287	5315-00-011-9120	C1	9
96906	MS24665-423		C1	18
96906	MS27183-14	5310-00-080-6004	C1	5
96906	MS27183-18	5310-00-809-5998	C1	31
96906	MS27183-19	5310-00-809-3079	C1	8
96906	MS27183-25	5310-00-809-8540	C1	16
96906	MS35206-25	5305-00-984-4988	C1	33
96906	MS35206-261	5305-00-984-6208	C1	2
96906	MS35206-280	5305-00-988-1724	C1	27
96906	MS35338-41	5310-00-045-4007	C1	32
96906	MS35338-43	5310-00-045-3296	C1	3
96906	MS35338-46	5310-00-637-9541	C1	18
96906	MS35338-65	5310-00-011-5093	C1	24
96906	MS35489-81	5325-00-270-8889	C1	28
96906	MS35671-41	5315-00-290-9244	C1	10
96906	MS35692-1202		C1	1A
96906	MS39086-174	5315-00-882-0904	C1	15
96906	MS51967-2		C1	26
96906	MS51968-14	5310-00-732-0560	C1	36
96906	MS51968-2	5310-00-768-0319	C1	22
96906	MS51968-8	5310-00-732-0559	C1	25
96906	MS90725-59		C1	30
96906	MS90726-115	5305-00-226-7768	C1	34
96906	MS90726-60	5305-00-269-2803	C1	29
96906	MS90726-62	5305-00-269-2805	C1	7
52793	03-006394		C1	19A
52793	03-006404-M		C1	19G
52793	03-013021		C1	19K
60038	15123	3110-00-198-2169	C1	19E
60038	15245	3110-00-198-2170	C1	19F
52793	22011		C1	23
52793	22063		C1	13
52793	22167		C1	1
60038	24720	3110-00-100-0542	C1	19H
60038	24780	3110-00-100-3537	C1	19J

## NATIONAL STOCK NUMBER AND PART NUMBER INDEX

## PART NUMBER INDEX

FSCM	PART NUMBER	STOCK NUMBER	FIG	ITEM
52793	38190		C1	4
52793	38284		C1	35
52793	38297-1		C1	14
52793	38297-2		C1	14A
52793	38313		C1	11
98750	48B7385		C1	17
81996	4920-EG-086-3		C1	19D
81996	4920-EG-092-1		C1	38
81996	4920-EG-092-2		C1	39
81996	4920-EG-092-3		C1	40
73808	6-00X9	2610-00-089-5997	C1	21

## ALPHABETICAL INDEX

TM 55-1730-224-13 &amp; P

Subject, Paragraph

## A

Adjustment of tie rods, 3-18  
 Adjustment of wheel bearings, 3-17  
 Assembly - Bolster assembly to  
   frame tubes, 3-7  
   - corner assembly to frame  
   tubes, 3-6  
   - pallet assembly to  
   bolsters, 3-8  
   - jacks to frame  
   tubes, 3-13  
   - rails to pallets, 3-12  
   - tie rods to tongue and  
   corner assembly, 3-10  
   - tongue to frame, 3-9  
   - towbar to tongue, 3-11  
 Assembly, order of, 3-5

## B

bearing, spindle, repair of, 3-24  
 before you operate, 2-2  
 bolster assembly to frame tubes,  
   assembling 3-7  
 bolster, pallet and Summary of  
   Maintenance, 3-39  
 bolster, removing, 3-40  
 brake assembly, remove and  
   install, 3-31  
 bushings, repair, 3-24

## C

capabilities, 1-6  
 characteristics, 1-6  
 checking - unpacked equipment, 3-4  
   - tie rod adjustment, 3-18  
 common tools, 3-1  
 controls, operator's, 2-1  
 coupling rails, operating  
   instructions, 2-4  
 coupling rails, warning coupling  
   and towing instructions, 2-4

Subject, Paragraph

## D

description and use of operator's  
   controls, 2-1  
 destruction to prevent enemy use, 2-1  
 diagram, wiring, 3-39

## E

enemy use, destruction to  
   prevent, 1-3  
 errors, reporting of, 1-4  
 equipment, support, 3-2

## F

failure to operate, 2-3  
 features, 1-6  
 forms, maintenance, 1-2  
 frame, principles of  
   operation, 1-7  
 front axle and steering assembly,  
   Summary of Maintenance, 3-25

## G

grease fitting, lubrication, 3-16

## I

Improvement, reporting recommen-  
   dations, 1-5  
 Installing -  
   bolsters, 3-40  
   brake assembly, 3-31  
   kingpins, 3-28  
   pallet, 2-6  
   rail couplers, 3-37  
   rail stops, 3-38  
   rear corner assemblies, 3-33  
   tire and tube, 3-35  
 Instructions, operating, 2-1

## J

jacking, warning, 2-1  
 jacks, operating, 2-7  
 jacks, to frame tubes, assembly  
   of, 3-13

ALPHABETICAL INDEX (cont)

Subject, Paragraph

K

Kingpins

-installing, 3-28

- removing, 3-28

L

leading particulars, 1-6

lifting pallets, warning, 3-16

lubrication of grease

fittings, 3-16

lubrication of wheel bearings, 3-17

M

Maintenance Allocation Chart, App. B

Maintenance forms, 1-2

Maintenance, prevention, before operating, 2-2

Maintenance, preventive procedures,

Maintenance, Summary of

- brake, 3-30

- front axle and steering, 3-25  
assembly, 3-39

- pallet and bolster

- rail assembly, 3-36

- rear axle, 3-32

- tow bar, 3-20

- wheel assembly, 3-24

P

pallet and bolster, Summary of Maintenance, 3-39

pallet assy to bolster, assembly of, 3-8

pallet, principles of operation, 1-8

parking, warning, parts, repair, 3-3

preliminary servicing of equipment, 3-14

pressure, tires, 3-15

preventive maintenance before operating, 2-2

preventive maintenance before you operate, 2-2

preventive maintenance procedures, particulars, leading, 1-10

Index 2

Subject, Paragraph

P

principles of operation

- frame, 1-8

- pallet, 1-9

- rails, 1-10

R

rail assembly, Summary of Maintenance, 3-36

rail couplers, removing and installing, 3-37

rails, coupling, operating instructions, 2-5

rails, principles of operation, rear axle, Summary of Maintenance

receipt, service upon , 3-4 - 3-18

records, 1-2

references, A-1

removing

-bolsters, 3-40

-brake assembly, 3-31

-front corner assembly, 3-27

-kingpins, 3-28

-pallets, 2-6

-rail couplers, 3-37

-rail stops, 3-38

-rear corner assemblies, 3-33

-spindle bearings, 3-29

-tire and tube, 3-35

repair of

-spindle bearings, 3-29

repair parts, App.C

reporting of errors, 1-2

reports, 1-2

S

Scope of manual, 1-1

Service upon receipt, 3-4 - 3-18

Servicing, preliminary of equipment, 3-14

Special tools, 3-2

Spindle, repair of bearings, 3-29

Summary of Maintenance

-brake, 3-30

-front axle, 3-25

-pallet and bolster, 3-39

-rail assembly, 3-36

-rear axle, 3-32

-towbar, 3-20

ALPHABETICAL INDEX (cont)

Subject, Paragraph

S (cont)

- wheel assembly, 3-24  
Support equipment, 3-2

T

Table of Contents  
tie rod, adjusting, 3-18  
tie rod, checking adjustment, 3-18  
tie rod, removing, 3-21  
tie rods to tongue and corner  
assembly, 3-10  
tire and tube, removing and  
installing, 3-35  
tire pressure, 3-15  
TMDE, 3-2  
tools, common, 3-1  
tools, special, 3-2  
tongue to frame, assembly of, 3-9  
towbar to tongue, assembling, 3-11

Subject, Paragraph

towing, coupling, and operating  
instructions, 2-4  
towing, warning  
troubleshooting

U

unpacked equipment, checking, 3-4  
use, description and of operator's  
controls, 2-1  
usual conditions, operation  
under, 2-4 -2-7

W

wheel assembly, Summary of  
Maintenance, 3-34  
wheel bearings, adjustment, 3-17  
wheel bearings, lubrication  
of, 3-17  
wiring diagram, 3-39



THEN... JOT DOWN THE DOPE ABOUT IT ON THIS FORM, CAREFULLY TEAR IT OUT, FOLD IT AND DROP IT IN THE MAIL!

SOMETHING WRONG WITH THIS PUBLICATION?

FROM: (PRINT YOUR UNIT'S COMPLETE ADDRESS)  
**PFC JOHN DOE**  
**COA, 3d ENGINEER BN**  
**FT. LEAVELAND, MO 63108**  
 DATE SENT

PUBLICATION NUMBER: **TM 55-1730-224-13 & P**  
 PUBLICATION DATE: **15 Sep 82**  
 PUBLICATION TITLE: **Trailer, Aircraft Maint Airmobile**

BE EXACT... PIN-POINT WHERE IT IS				IN THIS SPACE TELL WHAT IS WRONG AND WHAT SHOULD BE DONE ABOUT IT:
PAGE NO.	PARA-GRAPH	FIGURE NO.	TABLE NO.	
<b>6</b>	<b>2-1 a</b>			<i>In line 6 of paragraph 2-1a the manual states the engine has <u>6</u> Cylinders. The engine on my set only has <u>4</u> Cylinders. Change the manual to show <u>4</u> Cylinders.</i>
<b>B1</b>		<b>4-3</b>		<i>Callout 16 on figure 4-3 is pointing at a <u>bolt</u>. In key to figure 4-3, item 16 is called a <u>skin</u> - Please correct one or the other.</i>
<b>125</b>	<b>line 20</b>			<i>I ordered a gasket, item 19 on figure B-16 by NSN 2 910-05-762-3001. I got a gasket but it doesn't fit. Supply says I got what I ordered, so the NSN is wrong. Please give me a good NSN</i>

TEAR ALONG PERFORATED LINE

PRINTED NAME, GRADE OR TITLE, AND TELEPHONE NUMBER: **JOHN DOE, PFC (268) 317.7111**  
 SIGN HERE: **JOHN DOE**

FILL IN YOUR  
UNIT'S ADDRESS

FOLD BACK

DEPARTMENT OF THE ARMY

OFFICIAL BUSINESS

COMMANDER  
U S ARMY SUPPORT AND AVIATION MATERIEL READINESS COMMAND  
ATTN: DRSTS-MPSD  
4300 GOODFELLOW BOULEVARD  
ST. LOUIS, MO 63120

TEAR ALONG PERFORATED LINE





FILL IN YOUR  
UNIT'S ADDRESS

FOLD BACK

DEPARTMENT OF THE ARMY

OFFICIAL BUSINESS

COMMANDER  
U S ARMY SUPPORT AND AVIATION MATERIEL READINESS COMMAND  
ATTN: DRSTS-MPSD  
4300 GOODFELLOW BOULEVARD  
ST. LOUIS, MO 63120

TEAR ALONG PERFORATED LINE



FILL IN YOUR  
UNIT'S ADDRESS

FOLD BACK

DEPARTMENT OF THE ARMY

OFFICIAL BUSINESS

COMMANDER  
U S ARMY SUPPORT AND AVIATION MATERIEL READINESS COMMAND  
ATTN: DRSTS-MPSD  
4300 GOODFELLOW BOULEVARD  
ST. LOUIS, MO 63120

TEAR ALONG PERFORATED LINE

RECOMMENDED CHANGES TO EQUIPMENT TECHNICAL PUBLICATIONS



THEN... JOT DOWN THE DOPE ABOUT IT ON THIS FORM. CAREFULLY TEAR IT OUT. FOLD IT AND DROP IT IN THE MAIL!

**SOMETHING WRONG WITH THIS PUBLICATION?**

FROM: (PRINT YOUR UNIT'S COMPLETE ADDRESS)

DATE SENT

PUBLICATION NUMBER

TM 55-1730-224-13 & P

PUBLICATION DATE

15 Sep 82

PUBLICATION TITLE

Trailer, Aircraft Maint Airmobile

BE EXACT... PIN-POINT WHERE IT IS

PAGE NO.	PARA-GRAPH	FIGURE NO.	TABLE NO.

IN THIS SPACE TELL WHAT IS WRONG AND WHAT SHOULD BE DONE ABOUT IT:

PRINTED NAME, GRADE OR TITLE, AND TELEPHONE NUMBER

SIGN HERE:

DA FORM 2028-2  
1 JUL 79

PREVIOUS EDITIONS ARE OBSOLETE.  
DRSTS-M Overprint 2, 1 Nov 80.

P.S.--IF YOUR OUTFIT WANTS TO KNOW ABOUT YOUR RECOMMENDATION MAKE A CARBON COPY OF THIS AND GIVE IT TO YOUR HEADQUARTERS.

FILL IN YOUR  
UNIT'S ADDRESS

FOLD BACK

DEPARTMENT OF THE ARMY

\_\_\_\_\_  
\_\_\_\_\_

OFFICIAL BUSINESS

COMMANDER  
U S ARMY SUPPORT AND AVIATION MATERIEL READINESS COMMAND  
ATTN: DRSTS-MPSD  
4300 GOODFELLOW BOULEVARD  
ST. LOUIS, MO 63120

TEAR ALONG PERFORATED LINE

RECOMMENDED CHANGES TO EQUIPMENT TECHNICAL PUBLICATIONS



THEN... JOT DOWN THE DOPE ABOUT IT ON THIS FORM, CAREFULLY TEAR IT OUT, FOLD IT AND DROP IT IN THE MAIL!

SOMETHING WRONG WITH THIS PUBLICATION?

FROM (PRINT YOUR UNIT'S COMPLETE ADDRESS)  
 CDR, 1st Br, 65th ADA  
 ATTN: SP4 J. Brown  
 Key West, FL 33040

DATE SENT  
 10 Jun 79

PUBLICATION NUMBER  
 TM 9-1430-550-34-1

PUBLICATION DATE  
 7 Sep 72 .

PUBLICATION TITLE Unit of Radar Set  
 AN/MPQ-50 Tested at the HFC

BE EXACT PIN-POINT WHERE IT IS

PAGE NO	PARA-GRAPH	FIGURE NO	TABLE NO
9-19		9-5	
21-2	step 1C	21-2	

SAMPLE

IN THIS SPACE TELL WHAT IS WRONG AND WHAT SHOULD BE DONE ABOUT IT:

"B" Ready Relay K11 is shown with two #9 contacts. That contact which is wired to pin 8 of relay K16 should be changed to contact #10.

Reads: Multimeter B indicates 600 K ohms to 9000 K ohms.

Change to read: Multimeter B indicates 600 K ohms minimum.

Reason: Circuit being checked could measure infinity. Multimeter can read above 9000 K ohms and still be correct.

PRINTED NAME GRADE OR TITLE AND TELEPHONE NUMBER

SP4 J.T. Brown, Jr.

SIGN HERE

SP4 James Brown, Jr.

DA FORM 2028-2 2 JUL 79

REPLACES DA FORM 2028-2 1 APR 78 WHICH WILL BE USED UNTIL EXHAUSTED AMM/V M Overprint 3, 1 Mar 91

P.S.--IF YOUR OUTFIT WANTS TO KNOW ABOUT YOUR RECOMMENDATION MAKE A CARBON COPY OF THIS AND GIVE IT TO YOUR HEADQUARTERS

1 Nov 80

FILL IN YOUR  
UNITS ADDRESS



FOLD BACK

DEPARTMENT OF THE ARMY

---

---

OFFICIAL BUSINESS

COMMANDER  
U.S. ARMY AVIATION AND TROOP COMMAND  
ATTN: AMSAT-I-MP  
4300 GOODFELLOW BOULEVARD  
ST. LOUIS, MO 63120-1798

TEAR ALONG PERFORATED LINE





1 Nov 80

FILL IN YOUR  
UNITS ADDRESS



FOLD BACK

DEPARTMENT OF THE ARMY

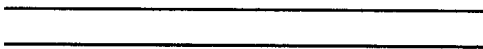

OFFICIAL BUSINESS

COMMANDER  
U.S. ARMY AVIATION AND TROOP COMMAND  
ATTN: AMSAT-I-MP  
4300 GOODFELLOW BOULEVARD  
ST. LOUIS, MO 63120-1798

TEAR ALONG PERFORATED LINE



FILL IN YOUR  
UNITS ADDRESS



FOLD BACK

DEPARTMENT OF THE ARMY

---

---

OFFICIAL BUSINESS

COMMANDER  
U.S. ARMY AVIATION AND TROOP COMMAND  
ATTN: AMSAT-I-MP  
4300 GOODFELLOW BOULEVARD  
ST. LOUIS, MO 63120-1798

TEAR ALONG PERFORATED LINE

RECOMMENDED CHANGES TO EQUIPMENT TECHNICAL PUBLICATIONS



THEN... JOT DOWN THE DOPE ABOUT IT ON THIS FORM. CAREFULLY TEAR IT OUT. FOLD IT AND DROP IT IN THE MAIL!

**SOMETHING WRONG WITH THIS PUBLICATION?**

FROM: (PRINT YOUR UNIT'S COMPLETE ADDRESS)

DATE SENT

PUBLICATION NUMBER

TM 55-1730-224-13&P

PUBLICATION DATE

15 SEP 82

PUBLICATION TITLE

TRAILER, AIRCRAFT MAINTENANCE, AIRMOBILE

BE EXACT. PIN-POINT WHERE IT IS

PAGE NO	PARA-GRAPH	FIGURE NO	TABLE NO

IN THIS SPACE TELL WHAT IS WRONG AND WHAT SHOULD BE DONE ABOUT IT:

PRINTED NAME GRADE OR TITLE AND TELEPHONE NUMBER

SIGN HERE

1 Nov 80

FILL IN YOUR  
UNITS ADDRESS



FOLD BACK

DEPARTMENT OF THE ARMY

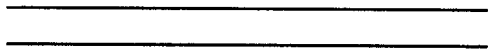

OFFICIAL BUSINESS

COMMANDER  
U.S. ARMY AVIATION AND TROOP COMMAND  
ATTN: AMSAT-I-MP  
4300 GOODFELLOW BOULEVARD  
ST. LOUIS, MO 63120-1798

TEAR ALONG PERFORATED LINE

# The Metric System and Equivalents

## Linear Measure

1 centimeter = 10 millimeters = .39 inch  
 1 decimeter = 10 centimeters = 3.94 inches  
 1 meter = 10 decimeters = 39.37 inches  
 1 dekameter = 10 meters = 32.8 feet  
 1 hectometer = 10 dekameters = 328.08 feet  
 1 kilometer = 10 hectometers = 3,280.8 feet

## Weights

1 centigram = 10 milligrams = .15 grain  
 1 decigram = 10 centigrams = 1.54 grains  
 1 gram = 10 decigrams = .035 ounce  
 1 dekagram = 10 grams = .35 ounce  
 1 hectogram = 10 dekagrams = 3.52 ounces  
 1 kilogram = 10 hectograms = 2.2 pounds  
 1 quintal = 100 kilograms = 220.46 pounds  
 1 metric ton = 10 quintals = 1.1 short tons

## Liquid Measure

1 centiliter = 10 milliliters = .34 fl. ounce  
 1 deciliter = 10 centiliters = 3.38 fl. ounces  
 1 liter = 10 deciliters = 33.81 fl. ounces  
 1 dekaliter = 10 liters = 2.64 gallons  
 1 hectoliter = 10 dekaliters = 26.42 gallons  
 1 kiloliter = 10 hectoliters = 264.18 gallons

## Square Measure

1 sq. centimeter = 100 sq. millimeters = .155 sq. inch  
 1 sq. decimeter = 100 sq. centimeters = 15.5 sq. inches  
 1 sq. meter (centare) = 100 sq. decimeters = 10.76 sq. feet  
 1 sq. dekameter (are) = 100 sq. meters = 1,076.4 sq. feet  
 1 sq. hectometer (hectare) = 100 sq. dekameters = 2.47 acres  
 1 sq. kilometer = 100 sq. hectometers = .386 sq. mile

## Cubic Measure

1 cu. centimeter = 1000 cu. millimeters = .06 cu. inch  
 1 cu. decimeter = 1000 cu. centimeters = 61.02 cu. inches  
 1 cu. meter = 1000 cu. decimeters = 35.31 cu. feet

## Approximate Conversion Factors

To change	To	Multiply by	To change	To	Multiply by
inches	centimeters	2.540	ounce-inches	newton-meters	.007062
feet	meters	.305	centimeters	inches	.394
yards	meters	.914	meters	feet	3.280
miles	kilometers	1.609	meters	yards	1.094
square inches	square centimeters	6.451	kilometers	miles	.621
square feet	square meters	.093	square centimeters	square inches	.155
square yards	square meters	.836	square meters	square feet	10.764
square miles	square kilometers	2.590	square meters	square yards	1.196
acres	square hectometers	.405	square kilometers	square miles	.386
cubic feet	cubic meters	.028	square hectometers	acres	2.471
cubic yards	cubic meters	.765	cubic meters	cubic feet	35.315
fluid ounces	milliliters	29.573	cubic meters	cubic yards	1.308
pints	liters	.473	milliliters	fluid ounces	.034
quarts	liters	.946	liters	pints	2.113
gallons	liters	3.785	liters	quarts	1.057
ounces	grams	28.349	liters	gallons	.264
pounds	kilograms	.454	grams	ounces	.035
short tons	metric tons	.907	kilograms	pounds	2.205
pound-feet	newton-meters	1.356	metric tons	short tons	1.102
pound-inches	newton-meters	.11296			

## Temperature (Exact)

°F	Fahrenheit temperature	5/9 (after subtracting 32)	Celsius temperature	°C
----	------------------------	----------------------------	---------------------	----

